

GreenLine - GLM

MECHANICAL DIAPHRAGM METERING PUMP

PULSAFEEDER.COM/GREENLINE-PUMP



Max Flow: up to 824 gph (3,120 lph)



Pressure: up to 174 psi (12 bar)



Temperature: 32 - 113°F (0 - 45°C)



Accuracy: +/- 2% of Set Point



 **PULSAFEEDER®**

MECHANICAL DIAPHR

PULSAFEEDER EXPERTISE

For over 80 years, Pulsafeeder, Inc. continues to be a proven leader in diaphragm and dosing metering technologies. With extensive experience in providing fluid handling solutions, our pumps and systems are designed to handle your toughest applications. Known for their rugged construction and dependable performance, our products are of the highest level of manufacturing excellence and quality control.

GREENLINE SERIES PUMPS

Our GreenLine series is a mechanically actuated diaphragm metering pump, designed to be reliable, robust, efficient, and compact. It features an industrial design to work in just about any application or environment. If you are looking for a high value chemical transfer or dosing metering pump with low cost of ownership, GreenLine-GLM is an outstanding choice. This latest pump series from Pulsafeeder can handle a wide range of flows and process chemicals.

MATERIALS OF CONSTRUCTION

Wet End Materials: PVDF, 316L Stainless Steel
Diaphragms: Composite PTFE
Check Valves: Ceramic or Stainless Steel

Housing: Epoxy Painted Aluminum
Lubrication: Oil Bath
Hardware: Stainless Steel



DM 1-2



DM 3-4



DM 5-6



DM 7

Design Feature	Customer Benefit
Robust industrial design	Long pump life, low cost of ownership
Auto stroke adjustment lock	Accurate chemical dosing
Leak free wet end with secondary sealing	Safety, no clean up or environmental risks
Toolless valve and connection options	Fast and easy installation and servicing
Multiple KOPkit® service options	Proper level of maintenance with minimized cost
Epoxy paint and ETFE coated heads	Chemical resistant and protected from the environment
Fully sealed outdoor-duty gearbox	Sealed and protected from harsh environments
Oil sight glass	Quick maintenance checks
Never-seize coupling	Allows for quick and easy removal of motor

MARKETS & TYPICAL APPLICATIONS

Markets









- Water Treatment
- Wastewater Treatment
- Cooling Towers Boilers
- Power Generation
- Chemical
- Petrochemical
- Food and Beverage
- Pharmaceutical
- Mining

Typical Applications

- Acids
- Caustics
- Polymers
- Bleaches
- pH Control
- Solvents
- Dyes / Inks
- Catalysts
- Cleaning Agents

AGM METERING PUMP

PRODUCT SPECIFICATIONS

 Max Flow: up to 824 gph (3,120 lph)	 Pressure: up to 174 psi (12 bar)	 Process Temperature: from 32 - 113°F (0 - 45°C)	 Accuracy: +/- 2% of Set Point
Min Flow: 3.2 gph (12 lph)	Suction Lift: 10 ft (3 m)	Ambient Temperature Range: from 32 - 113°F (0 - 45°C)	
 Stroke Adjustment: 0-100%, resolution 1.0%, Auto-locking	 Standard Viscosity: up to 1,000 cPs	 Modular Connections: Threaded, Flanged	 Chemical Compatibility: PVDF, 316L SS, PTFE & Viton wet end component options
	NPIP Pressure: 5 psi (0.4 bar)		

DIAPHRAGM TECHNOLOGY

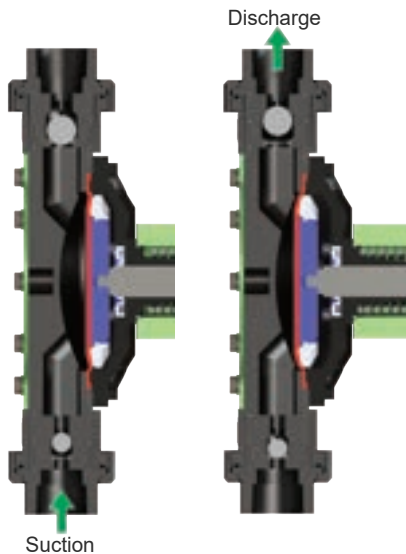

A diaphragm reciprocates at a preset stroke length, displacing an exact volume of process fluid. Diaphragm retraction causes the product to enter through the suction check valve. Diaphragm advancement causes the discharge of an equal amount of the product through the discharge check valve.

HEAVY DUTY DIAPHRAGM

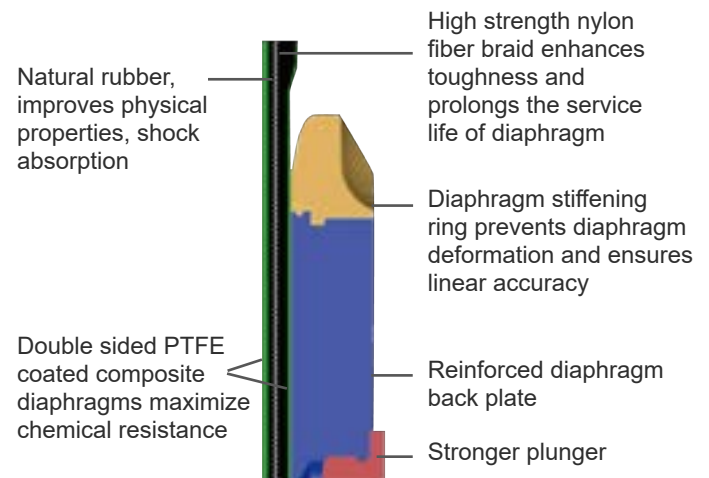

LEAK FREE PUMP HEAD

The safe diaphragm sealing design ensures no leakage.

The check valve with multiple O-ring seals can effectively prevent the leakage of chemicals.

The heavy-duty pump head support bracket design ensures the torque of the pump head bolts and prevents loosening.

There are multiple liquid end material options available, compatible with a wide variety of chemicals to insure leak-free dosing.



LEAK DETECTION (OPTIONAL)

Safeguard your pump and system from costly product loss and equipment damage.

The leak detection double diaphragm option comes with a pressure gauge and switch to monitor the diaphragm integrity.

The two diaphragms give you superior protection from a diaphragm failure.

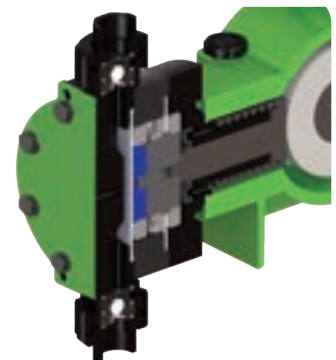

FEATURES & BENEFITS



GEARBOX

- Compact and lightweight - saves space and easy to handle
- Fully sealed, non-vented gearbox design prevents ingress of contaminants
- Oversized, shielded bearings for long life and reliability
- Robust industrial hex-head SS hardware suitable for harsh industrial uses



MOUNTING FEET

- Flat and solid uniform mounting feet - extend outside of the gearbox for stability
- Oversized, slotted mounting holes to accommodate various fasteners
- With motor installed, pump will not tip over prior to installation



DRIVE

- Sealed upper worm bearing extends gear and motor life, reduces noise, and maximizes pump efficiencies by ensuring full torque output
- Motor flange drain path redirects liquids away from seal and eliminates pooling / resting on seal or motor shaft connection
- Non-metallic, never-seize motor coupling prevents sticking or "welding" of worm shaft to motor shaft allowing for ease of motor installation / removal
- Highly efficient, heavy-duty drive train maximizes uptime and reduces total cost of ownership
- Maximize operating range and remotely control with variable frequency drive and motor (optional)



OIL LUBRICATION

- Oil bath for normal or explosion proof areas - lubricates all internal moving parts to extend pump life
- Easy and accessible oil fill location - obstruction free and visible



WET END & CONNECTIONS

- Standard materials: PVDF, 316L SS
- Stainless Steel hardware for added chemical resistance
- Four bolt tiebar (316L models only)
- Standard FNPT and ANSI Flanged connections





LEAK FREE HEAD

- Secure diaphragm sealing technology provides leak free service and chemical containment
- Secondary O-ring seal offers worry free valve sealing and eliminates chemical spray
- Retention plate ensures pressure containment (hydrostatic and creep elimination) and allows for proper head bolt torque without loosening over time



HEAVY DUTY DIAPHRAGM

- Flat mechanically actuated diaphragm delivers reliable pumping action and long life
- Double sided PTFE coated composite diaphragms maximize chemical resistance and diaphragm lubrication
- Multiple diaphragm sealing beads prevent leakage in industrial applications



CHECK VALVES

- Spherically uniform velocity valving limits turbulence, provides superior solids handling and is auto-flushing. Flow is routed evenly without risk of cavitation
- O-ring valve seat (soft seat) for improved priming, less noise, and better solids / slurry handling (not available in 316L configurations)



STROKE CONTROL

- 10:1 turndown standard
- 0-100% stroke range (while on or off) in one complete revolution
- Auto-lock stroke position, drift free - maintaining proper flow



SERVICING

- Toolless valve removal for simple servicing
- The pump head connector does not require a separate nut, making installation and maintenance more convenient
- Easy oil fill and drain
- Oil sight glass for fast inspection of oil and operation
- Ease of maintenance - common hardware, no special tools required
- Never-seize, non-metallic motor coupling for fast disconnect



FLOW & PRESSURE

FLOW CURVES

Only 60Hz speeds and flows are shown

DM1

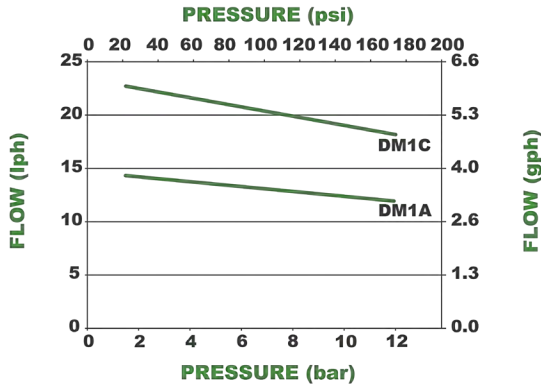

DM2

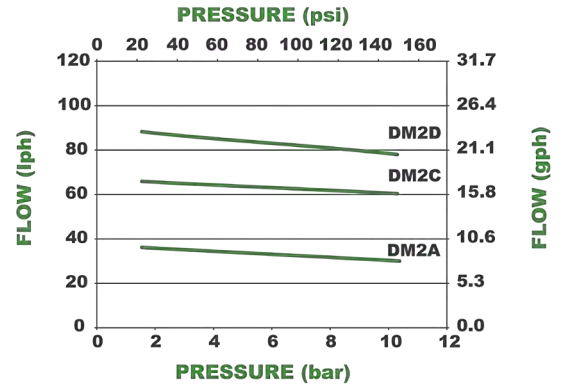

DM3

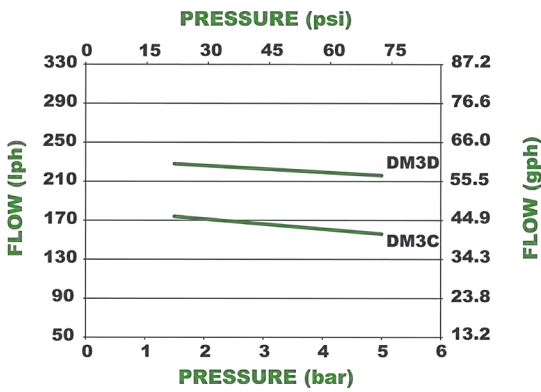

DM4

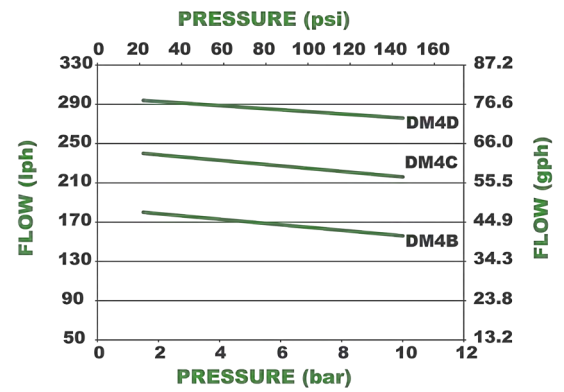

DM5

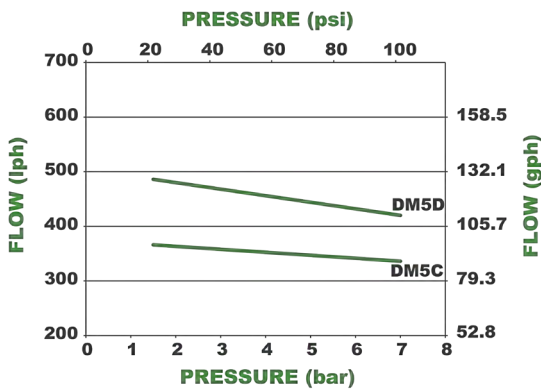

DM6

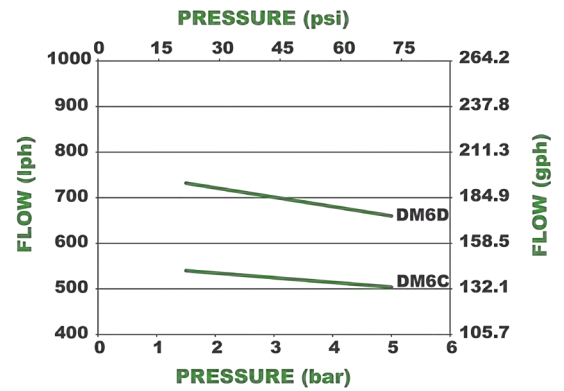

DM7 SIMPLEX

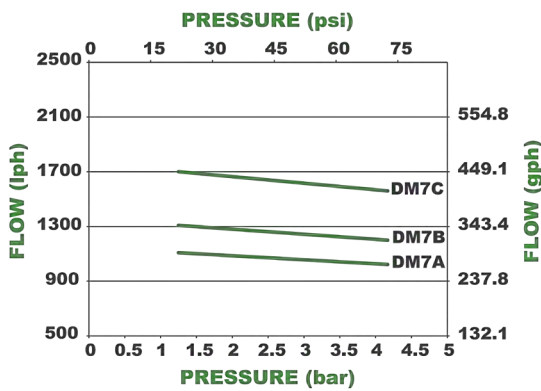

DM7 DUPLEX

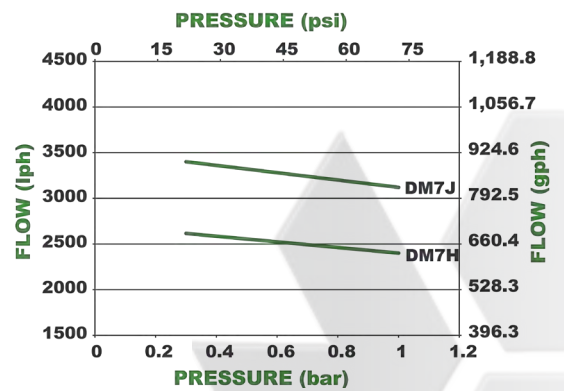

RATING

DM1-6 PUMP COMPONENTS

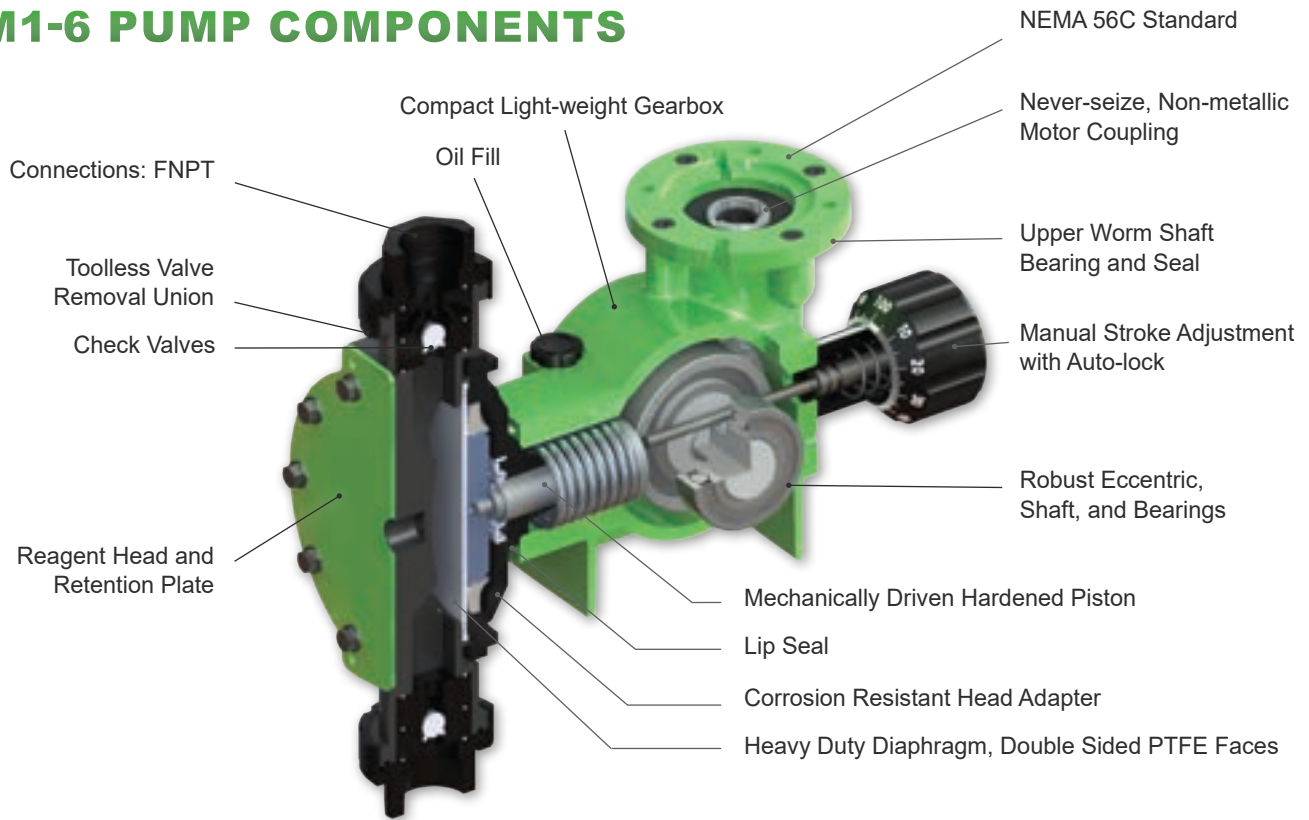

DM7 PUMP COMPONENTS

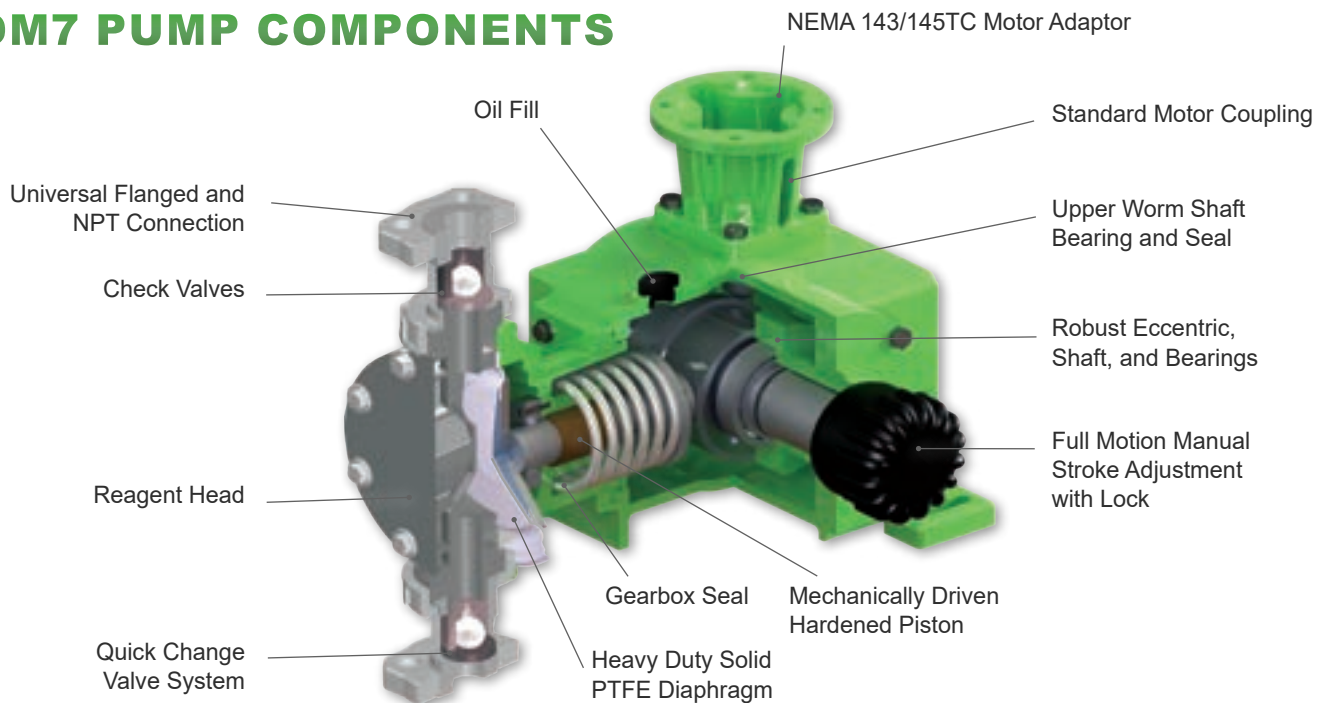

MODEL TABLE — FLOW & PRESSURE RATINGS

MODEL	60Hz Flow gph (lph)	Pressure psi (bar)	60Hz SPM @ 1750	Motor HP (kW) Required	Connection Size
DM1A	3.2 (12)	174 (12)	88	0.50 (0.37)	0.5" FNPT
DM1C	4.8 (18)		140		
DM2A	7.9 (30)	145 (10)	88		
DM2C	15.9 (60)		140		
DM2D	20.6 (78)		175		
DM3C	38 (144)	102 (7)	140		
DM3D	52.3 (198)		175		
DM4B	41.2 (156)	145 (10)	116		
DM4C	57 (216)		140		
DM4D	72.9 (276)		175		
DM5C	88.8 (336)	102 (7)	140	1.5 (1.1)	1.5" FNPT
DM5D	111 (420)		175		
DM6C	133 (504)	73 (5)	140		
DM6D	174 (660)		175		
DM7A	269.5 (1020)		116		
DM7B	317 (1200)	73 (5)	140		
DM7C	412 (1560)		175		
DM7H*	634 (2400)		140		
DM7J*	824.2 (3120)		175		

*Duplex-head pump model

DM1-7 PUMP MODEL CONFIGURATION

Pump Selection	Code	Choice and Description	DM_ _ _ _ _						
PUMP SIZE POSITION 1-4	See Chart	Select Pump from Model Table on Page 8							
MOTOR SELECTION POSITION 5	1	TEFC, 115/230V, 60Hz, 1PH	<table border="1"> <thead> <tr> <th>Pump Size</th> <th>Motor Frame</th> </tr> </thead> <tbody> <tr> <td>DM1-6</td> <td>NEMA 56C Frame</td> </tr> <tr> <td>DM7</td> <td>NEMA 143/145 Frame</td> </tr> </tbody> </table>	Pump Size	Motor Frame	DM1-6	NEMA 56C Frame	DM7	NEMA 143/145 Frame
	Pump Size	Motor Frame							
	DM1-6	NEMA 56C Frame							
	DM7	NEMA 143/145 Frame							
3	TEFC, 230/460V, 60Hz, 3PH								
V	TEFC, 230/460V, 60Hz, 3PH with VFD								
Y	Without Motor, with Frame Adapter								
WET END MATERIALS POSITION 6	A	316 SS Liquid End / PTFE Diaphragm / PTFE O-rings / 316 SS Ball Valves							
	F	PVDF Liquid End / PTFE Diaphragm / Viton® O-rings / Ceramic Ball Valves / Viton® O-ring Seats							
CONNECTIONS POSITION 7	C	0.5 inch FNPT (DM 1-2 Only)							
	G	1 inch FNPT (DM 3-4 Only)							
	H	316 SS - 1.5 inch FNPT (DM5-7 Only)							
	H	PVDF - 1.5 inch FNPT (DM5-6 Only) / 1.5 inch FNPT and 1.5 inch ANSI 150# Flange Combination (DM7 Only)							
LEAK DETECTION POSITION 8-12	"Leave Blank"	No Leak Detection, With Motor							
	-NM	No Leak Detection, No Motor							
	-L	Leak Detection Option, With Motor: Double Diaphragm with Pressure Gauge and Switch (24VDC / 0.5 Amp Max)							
	-L-NM	Leak Detection Option, No Motor: Double Diaphragm with Pressure Gauge and Switch (24VDC / 0.5 Amp Max)							

KOPKIT® CONFIGURATION

KOPkit Selection	Pump Size	Choice and Description	KD_ _ _
PUMP SIZE POSITION 1-3	See Chart	Select Pump Size Number (1-7)	
WET END MATERIALS POSITION 4	A	316L SS / PTFE O-rings	
	F	PVDF / Viton® O-rings (Viton® O-ring Seat)	
LEAK DETECTION POSITION 5	X	Standard Single Diaphragm (No Leak Detection)	
	L	Leak Detection Option: Double Diaphragm	

KOPKIT® COMPONENTS

Quantities Included	KOPkit Components (DM1-7 Single Diaphragm)	
	PVDF	316 SS
KOPkit Components	Std	Std
Diaphragm	1	1
Valve O-Rings	6	6
Redundant O-Rings	2	0
Ball Valves	2	2
Valve Guides	2	2
Valve Seats	2	2
Valve O-Ring Seats	2	0

* Double Diaphragm KOPkit w/o Gauge & Valve
 ** DM1-2 w/o Valve O-Ring Seats

WET END MATERIALS

Wet End	Model	Head	Guide	Seat	Valve Cap	Check Balls	O-rings	O-ring Seat
PVDF	DM1-6	PVDF	PVDF	PVDF	PVDF	Ceramic	PTFE	Viton®
	DM7						Viton®	
316L SS	DM1-7	316L SS	316L SS	316L SS	316L SS	316L SS	PTFE	N/A

* Viton® is a registered trademark of DuPont Performance Elastomers.

D I M E N S I O N A L

DIMENSIONAL DRAWINGS

See Table Below

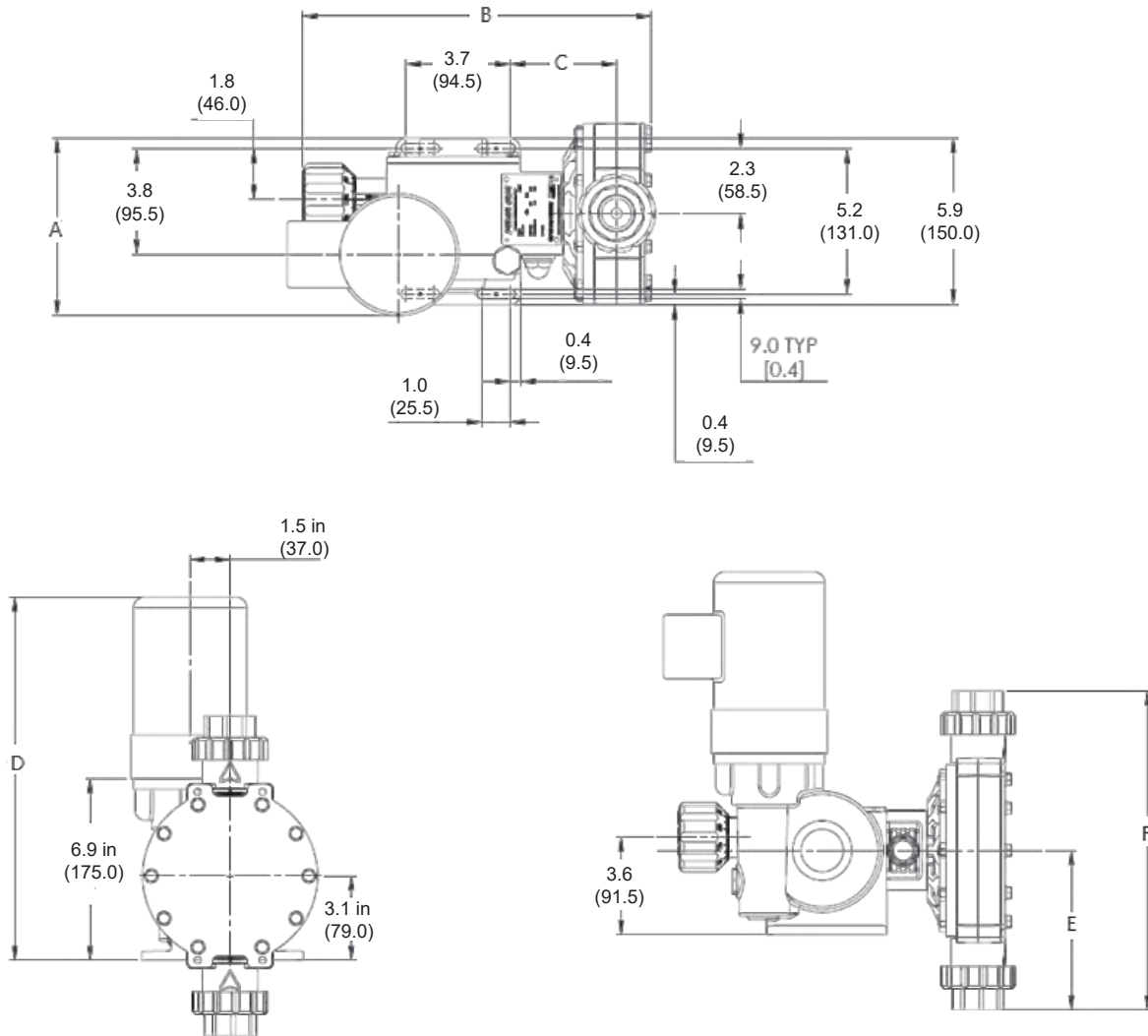

Model	Dimension								
	A	B	B w/ Leak DETN	C	C w/ Leak DETN	D Max	E Threaded	F Threaded	
DM1	56C	7.6 / 192.6	11.8 / 300.0	12.7 / 322.0	3.4 / 85.5	4.2 / 107.5	16.02 / 406.9	4.1 / 103.0	8.1 / 206.0
DM2	56C	7.6 / 192.6	11.8 / 300.0	12.7 / 322.0	3.4 / 85.5	4.2 / 107.5	16.02 / 406.9	4.1 / 103.0	8.1 / 206.0
DM3	56C	7.6 / 192.6	12.4 / 315.0	13.3 / 339.0	3.7 / 95.8	4.7 / 119.8	16.02 / 406.9	5.9 / 150.0	11.8 / 300.0
DM4	56C	7.6 / 192.6	12.4 / 315.0	13.3 / 339.0	3.7 / 95.8	4.7 / 119.8	18.3 / 464.8	5.9 / 150.0	11.8 / 300.0
DM5	56C	7.6 / 192.6	12.8 / 325.0	13.7 / 349.0	3.9 / 99.3	4.9 / 123.3	18.3 / 464.8	6.8 / 172.0	13.5 / 344.0
DM6	56C	7.6 / 192.6	12.8 / 325.0	13.7 / 349.0	3.9 / 99.3	4.9 / 123.3	18.3 / 464.8	6.8 / 172.0	13.5 / 344.0

All dimensions in inches (millimeters)

All measurements are for reference only. Subject to change.

DRAWINGS

DIMENSIONAL DRAWINGS DM7 SIMPLEX

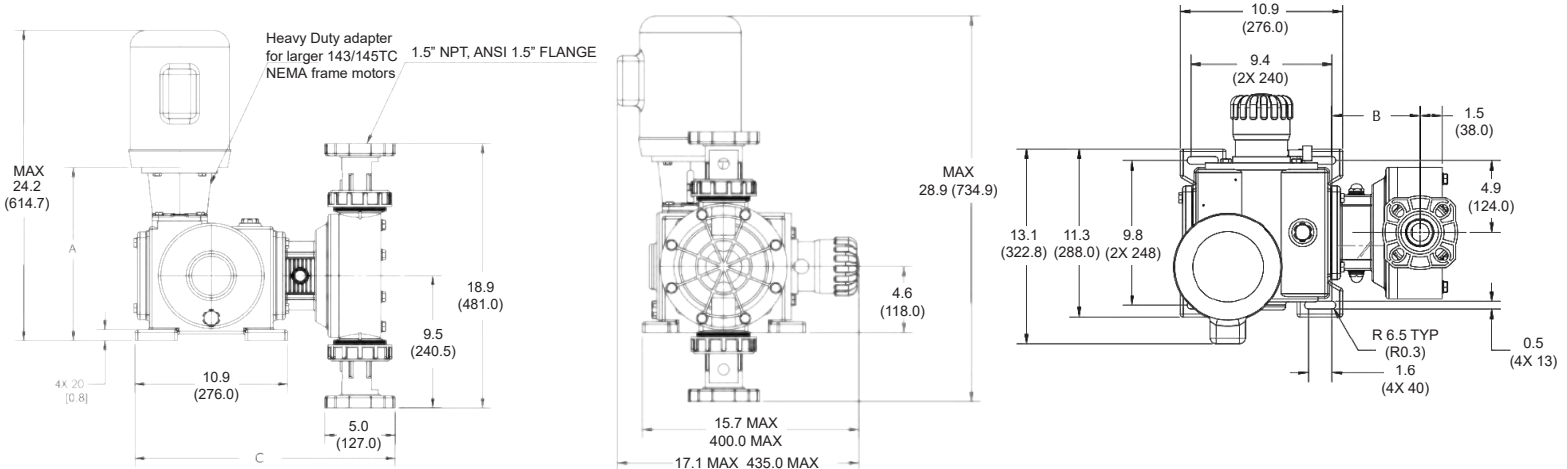

Frame	A	B w/o Leak DETN	B w/ Leak DETN	C w/o Leak DETN	C w/ Leak DETN
143/145TC	12.4 / 315.0	5.9 / 149.0	6.9 / 175.0	18.5 / 470.5	19.5 / 496.5

All dimensions in inches (millimeters)

DIMENSIONAL DRAWINGS DM7 DUPLEX

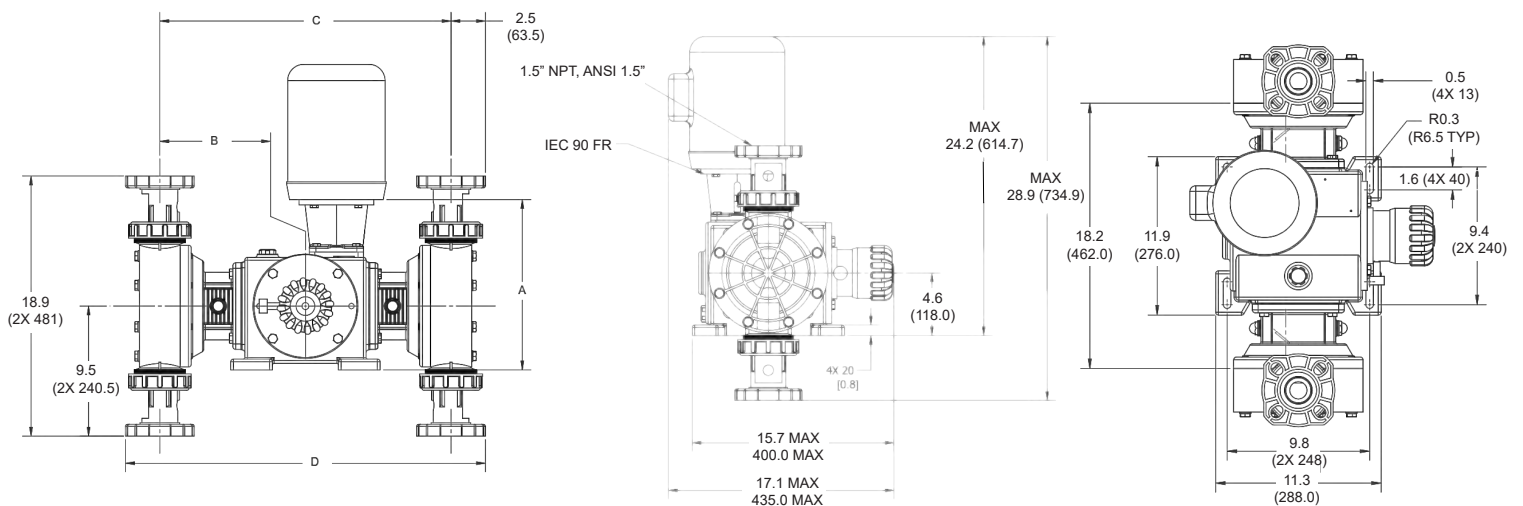

Frame	A	B w/o Leak DETN	B w/ Leak DETN	C w/o Leak DETN	C w/ Leak DETN	D w/o Leak DETN	D w/ Leak DETN
143/145TC	12.4 / 315.0	10.6 / 269.0	11.6 / 295.0	21.2 / 538.0	23.2 / 590.0	26.2 / 665.0	28.2 / 717.0

All dimensions in inches (millimeters)



PARTS, KITS, & ACCESSORIES



FNPT and ANSI Connections for convenient piping installations

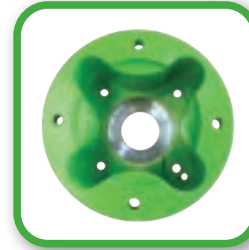

Heavy Duty Adapter for larger 143/145TC NEMA frame motors.



PULSALube is the only oil Pulsafeeder recommends for use in our pumps. PULSALube is a superior blend of oils designed to provide optimal lubrication and extend equipment life. It maintains your pump warranty.



We offer KOPkit® (Keep on Pumping kits) designed to guard against unnecessary downtime and assure the highest level of efficient and uninterrupted service from your GLM® pump. In the event of a breakdown, one kit will put you back in business fast!

