

D	=	143TC - 184C Frame, Double Containment Can						X	X		
R	=	1.125 inch Input Shaft, Single Containment Can								X	X
T	=	1.125 inch Input Shaft, Double Containment Can								X	X
STANDARD METRIC MOUNTING											
J	=	71 Frame, Single Containment Can (85.0 mm B.C.)	(4)	X	X						
K	=	80 Frame, Single Containment Can (100.0 mm B.C.)		X	X	X	X				
L	=	90 Frame, Single Containment Can (115.0 mm B.C.)				X	X				
P	=	100 Frame, Single Containment Can (130.0 mm B.C.)						X	X		
Q	=	100 Frame, Double Containment Can (130.0 mm B.C.)						X	X		
U	=	28 mm Input Shaft, Single Containment Can								X	X
V	=	28 mm Input Shaft, Double Containment Can								X	X
Position 9, 10 and 11 Options: Consult your local distributor to meet your special requirements.											

NOTE:

- (1) Maximum differential pressure allowed for plastic/plastic gears is 50 psig
- (2) Pumps with metallic drive and idler gears require minimum viscosity of 100 cPs and are limited to 1440 rpm maximum speed for GMC2-GMH8 pumps and 1150 rpm for GM12-16 pumps.
- (3) Ceramic wear plates with metallic gears require minimum viscosity of 100 cPs.
- (4) For GMC1 pump only: gears, wear plates and bearings are also available with indicated material or RYTON[®]; also available for NEMA 42C, 45C and IEC 63 motor frames

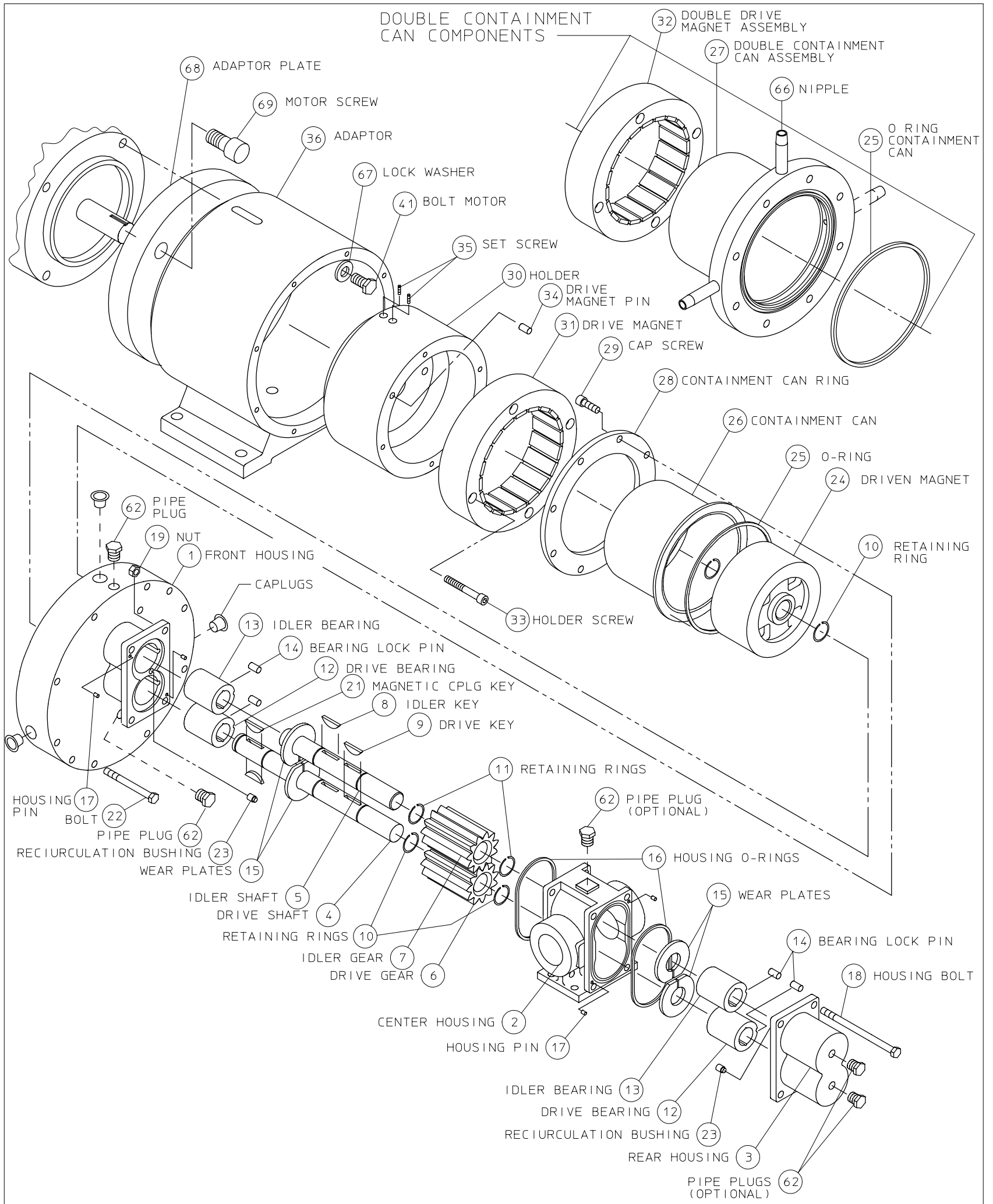

ALL DIMENSIONS ARE IN INCHES



MODEL GMH6/8
ISOICHEM PUMP
EXPLODED VIEW

SECTION/PAGE	MODEL GMH8 / 400
EFFECTIVE	10/10/00
SUPERSEDES	04/01/98

ADDED ITEM 67,68 & 69	10/10/00
REVISION UPDATE	DATE

DWN BY: CLA	SD-2776
DATE: 04/04/94	

ITEM CLASS GMH6 = IB
 PRODUCT LINE = H / ISOCHEM

ISOCHEM GMH6 SERIES PUMP CONSOLIDATED B / M

SECTION: MODEL GMH6
 PAGE: 200
 DATE REV.: 10/22/18
 SUPERSEDES: 11/12/12

DESCRIPTION	QTY	STANDARD PUMP MATERIAL						ITEM
		316 SS (A, K, OR U)		ALLOY C (C, M, OR V)		ALLOY 20 (D, N, OR W)		
		PART NUMBER	MATERIAL	PART NUMBER	MATERIAL	PART NUMBER	MATERIAL	

POSITION 3 STANDARD PUMP - NON-VARIABLE COMPONENTS

HOUSING, FRONT	1	49678	316 SS	49679	ALLOY C	49680	ALLOY 20	1
HOUSING, CENTER A FNPT	1	40002	316 SS	40006	ALLOY C	40008	ALLOY 20	2
HOUSING, CENTER K FBSPT		40011	316 SS	40023	ALLOY C	40017	ALLOY 20	2
HOUSING, CENTER U FLANGED		NG040065-316	316 SS	NG040065-HCO	ALLOY C	NG040065-020	ALLOY 20	2
HOUSING, REAR	1	40247	316 SS	40248	ALLOY C	40249	ALLOY 20	3
# RING, RETAINING 3/4"	4-6	46714	316 SS	46711	ALLOY C	46711	ALLOY C	10
# RING, RETAINING 5/8"	0-2	Y9901400-316	316 SS	Y9901400-HCO	ALLOY C	Y9901400-HCO	ALLOY C	11
# KEY, METAL DRIVE GEAR	*1	41937	316 SS	41903	ALLOY C	41905	ALLOY 20	8
# KEY, MTL/CBN IDLER GEAR	*1	41937	316 SS	41903	ALLOY C	41905	ALLOY 20	9
# KEY, PLASTIC IDLER GEAR		41938	316 SS	41904	ALLOY C	41906	ALLOY 20	9
# KEY, MAGNETIC CPLG - DRIVE	*2	41937	316 SS	41903	ALLOY C	41905	ALLOY 20	21
# PIN, BEARING LOCK	4	41811	TFE	41811	TFE	41811	TFE	14
# BUSHING, RECIRCULATION (.000)	1	99618-00	TFE	99618-00	TFE	99618-00	TFE	23
# O RING, CENTER HOUSING	2	41101	TFE	41101	TFE	41101	TFE	16
PIN, HOUSING	4	40801	316 SS	40801	316 SS	40801	316 SS	17
BOLT, HOUSING	4	62005	188 SS	62005	188 SS	62005	188 SS	18
NUT, HOUSING	4	62101	188 SS	62101	188 SS	62101	188 SS	19
PLUG, 1/8" NPT	*2	W772565-316	316 SS	52301	ALLOY C	52300	ALLOY 20	62
NAMEPLATE	1	41210	188 SS	41210	188 SS	41210	188 SS	--

POSITION 9, 10, AND 11 OPTIONS - DELETE CORRESPONDING STANDARD PUMP COMPONENT FROM B/M

V	HOUSING, CENTER - VENT FNPT	1	40002-2	316 SS	40006-2	ALLOY C	40008-2	ALLOY 20	2
	HOUSING, CENTER - VENT FBSPT		40011-2	316 SS	40023-2	ALLOY C	40017-2	ALLOY 20	2
	HOUSING, CENTER - VENT FLANGED		NG040066-316	316 SS	NG040066-HCO	ALLOY C	NG040066-020	ALLOY 20	2
	PLUG, 1/8" NPT	*1	W772565-316	316 SS	52301	ALLOY C	52300	ALLOY 20	62
A	HOUSING, REAR -BRG FLUSH	1	40247-2	316 SS	40248-2	ALLOY C	40249-2	ALLOY 20	3
	PLUG, 1/8" NPT	*2	W772565-316	316 SS	52301	ALLOY C	52300	ALLOY 20	62
	# PIN, BEARING LOCK	4	41812	316 SS	41813	ALLOY C	41814	ALLOY 20	14
B	# O RING, CENTER HOUSING	2	41107	SS / PFA	41107	SS / PFA	41107	SS / PFA	16
	# O RING, CONTANMENT CAN	1-2	W210422-002	SS / PFA	W210422-002	SS / PFA	W210422-002	SS / PFA	25
D	# BEARING, SLOTTED 3/4"	0-4	40442	CARBON	40442	CARBON	40442	CARBON	12
	# BEARING, SLOTTED 5/8"	0-2	40440	CARBON	40440	CARBON	40440	CARBON	13
R	HOUSING, REAR -RECIRCULATION	1	40247-3	316 SS	40248-3	ALLOY C	40249-3	ALLOY 20	3
	# BUSHING, RECIRCULATION (.060)	2	99618-06	TFE	99618-06	TFE	99618-06	TFE	23
	# WEAR PLATE, RECIRCULATION	4	40527	CARBON	40527	CARBON	40527	CARBON	15
	# WEAR PLATE, RECIRCULATION		40529	TFE (GF)	40529	TFE (GF)	40529	TFE (GF)	15
	# WEAR PLATE, RECIRCULATION		40528	CERAMIC	40528	CERAMIC	40528	CERAMIC	15
# WEAR PLATE, RECIRCULATION	40530		PEEK	40530	PEEK	40530	PEEK	15	
W	DRIVEN MAGNET ASSY (WELDED)	1	49715	316 SS	49716	ALLOY C	49717	ALLOY 20	24

*COMPONENT QUANTITY MAY BE CUMULATIVE OVER ENTIRE B / M

DWG: GMH6P200

DENOTES RECOMMENDED SPARE PART

ISOCHEM GMH6 SERIES PUMP CONSOLIDATED B / M

SECTION: MODEL GMH6
PAGE: 201
DATE REV.: 11 / 12 / 12
SUPERSEDES: 11 / 12 / 04

STANDARD PUMP MATERIAL		
316 SS (A, K, OR U)	ALLOY C (C, M, OR V)	ALLOY 20 (D, N, OR W)

DESCRIPTION	QTY	PART NUMBER	MATERIAL	PART NUMBER	MATERIAL	PART NUMBER	MATERIAL	ITEM
-------------	-----	-------------	----------	-------------	----------	-------------	----------	------

POSITION 4 & 5 DRIVE AND IDLER GEAR MATERIAL

A	# GEAR, DRIVE/IDLER	3/4"	1-2	40729	316 SS	-----	-----	6, 7
C	# GEAR, DRIVE/IDLER	3/4"	1-2	40612	ALLOY C	40612	ALLOY C	6, 7
E	# GEAR, IDLER	5/8"	1	40613	PEEK	40613	PEEK	7

POSITION 6 WEAR PLATE MATERIAL

K	# WEAR PLATE, SLOTTED			40511	CARBON	40511	CARBON	15
T	# WEAR PLATE, SLOTTED			40513	TFE (GF)	40513	TFE (GF)	15
Z	# WEAR PLATE, SLOTTED			40525	CERAMIC	40525	CERAMIC	15
E	# WEAR PLATE, SLOTTED			40526	PEEK	40526	PEEK	15

POSITION 7 SHAFT AND BEARING MATERIAL

STANDARD CONSTRUCTION										
K	# SHAFT, DRIVE		1	41415	316 SS	41423	ALLOY C	41424	ALLOY 20	4
	# SHAFT, IDLER	5/8"	1	41434	316 SS	41435	ALLOY C	41436	ALLOY 20	5
	# SHAFT, IDLER METAL GEAR	3/4"		41428	316 SS	41429	ALLOY C	41430	ALLOY 20	5
	# BEARING, DRIVE/IDLER SHAFT	3/4"	2-4	40436	CARBON	40436	CARBON	40436	CARBON	12
	# BEARING, IDLER SHAFT	5/8"	0-2	40432	CARBON	40432	CARBON	40432	CARBON	13
T	# SHAFT, DRIVE		1	41415	316 SS	41423	ALLOY C	41424	ALLOY 20	4
	# SHAFT, IDLER	5/8"	1	41434	316 SS	41435	ALLOY C	41436	ALLOY 20	5
	# SHAFT, IDLER METAL GEAR	3/4"		41428	316 SS	41429	ALLOY C	41430	ALLOY 20	5
	# BEARING, DRIVE/IDLER SHAFT	3/4"	2-4	40438	TFE (GF)	40438	TFE (GF)	40438	TFE (GF)	12
	# BEARING, IDLER SHAFT	5/8"	0-2	40434	TFE (GF)	40434	TFE (GF)	40434	TFE (GF)	13

EXTENDED LIFE - BEARINGS

L	# SHAFT, DRIVE		1	41415	316 SS	41423	ALLOY C	41424	ALLOY 20	4
	# SHAFT, IDLER	5/8"	1	41434	316 SS	41435	ALLOY C	41436	ALLOY 20	5
	# SHAFT, IDLER METAL GEAR	3/4"		41428	316 SS	41429	ALLOY C	41430	ALLOY 20	5
	# BEARING, DRIVE/IDLER SHAFT	3/4"	2-4	40437	EWCBN	40437	EWCBN	40437	EWCBN	12
	# BEARING, IDLER SHAFT	5/8"	0-2	40433	EWCBN	40433	EWCBN	40433	EWCBN	13

EXTENDED LIFE - BEARINGS AND SHAFTS

C	# SHAFT, DRIVE		1	41425	CW / 316 SS	41426	CW / ALY C	41427	CW / ALY20	4
	# SHAFT, IDLER	5/8"	1	41437	CW / 316 SS	41438	CW / ALY C	41439	CW / ALY20	5
	# SHAFT, IDLER METAL GEAR	3/4"		41431	CW / 316 SS	41432	CW / ALY C	41433	CW / ALY20	5
	# BEARING, DRIVE/IDLER SHAFT	3/4"	2-4	40437	EWCBN	40437	EWCBN	40437	EWCBN	12, 13
	# BEARING, IDLER SHAFT	5/8"	0-2	40433	EWCBN	40433	EWCBN	40433	EWCBN	13

CORROSION/WEAR ("CW") - BOTH SHAFTS

B	# SHAFT, DRIVE		1	41425	CW / 316 SS	41426	CW / ALY C	41427	CW / ALY20	4
	# SHAFT, IDLER	5/8"	1	41437	CW / 316 SS	41438	CW / ALY C	41439	CW / ALY20	5
	# SHAFT, IDLER METAL GEAR	3/4"		41431	CW / 316 SS	41432	CW / ALY C	41433	CW / ALY20	5
	# BEARING, DRIVE/IDLER SHAFT	3/4"	2-4	40439	SICBD	40439	SICBD	40439	SICBD	12, 13
	# BEARING, IDLER SHAFT	5/8"	0-2	40435	SICBD	40435	SICBD	40435	SICBD	13

*COMPONENT QUANTITY MAY BE CUMULATIVE OVER ENTIRE B / M

DENOTES RECOMMENDED SPARE PART

DWG: GMH6P201

ISOCHEM GMH6 SERIES PUMP CONSOLIDATED B / M

SECTION: MODEL GMH6
PAGE: 202
DATE REV.: 11 / 12 / 12
SUPERSEDES: 02 / 12 / 01

STANDARD PUMP MATERIAL		
316 SS (A, K, OR U)	ALLOY C (C, M, OR V)	ALLOY 20 (D, N, OR W)

DESCRIPTION	QTY	PART NUMBER	MATERIAL	PART NUMBER	MATERIAL	PART NUMBER	MATERIAL	ITEM
-------------	-----	-------------	----------	-------------	----------	-------------	----------	------

POSITION 8 MAGNETIC COUPLING COMPONENTS

COMMON PARTS	DRIVEN MAGNET ASSY	1	49697	316 SS	49707	ALLOY C	49708	ALLOY 20	24
	BOLT, FRONT HOUSING/ADAPTOR	8	W770407-188	188 SS	W770407-188	188 SS	W770407-188	188 SS	22
	# O RING, CONTAINMENT CAN	1	W210422-TFE	TFE	W210422-TFE	TFE	W210422-TFE	TFE	25
	SCREW, SET	2	W771004-030	STEEL	W771004-030	STEEL	W771004-030	STEEL	35
	PIN, DRIVE MAGNET/HOLDER	2	W771209-003	STEEL	W771209-003	STEEL	W771209-003	STEEL	34
	SCREW, SKHD DRIVE MAGNET/HOLDER	4	W770027-188	188 SS	W770027-188	188 SS	W770027-188	188 SS	33
	CAN, CONTAINMENT	1	49674	ALLOY C	49674	ALLOY C	49674	ALLOY C	26
	SCREW, CONTAINMENT CAN RING	8	W770021-188	188 SS	W770021-188	188 SS	W770021-188	188 SS	29

143/5TC, 184C FRAME COMPONENTS

COMMON PARTS	HOLDER, DRIVE MAGNET	1	49705	STEEL	49705	STEEL	49705	STEEL	30
	ADAPTOR, MOTOR	1	Y1100700-ALU	ALUMINUM	Y1100700-ALU	ALUMINUM	Y1100700-ALU	ALUMINUM	36
	BOLT, MOTOR	4	W770425-188	188 SS	W770425-188	188 SS	W770425-188	188 SS	41

SINGLE CONTAINMENT CAN COMPONENTS

O	DRIVE MAGNET ASSY	1	49702	STEEL	49702	STEEL	49702	STEEL	31
	RING, CONTAINMENT CAN	1	49719	316 SS	49719	316 SS	49719	316 SS	28

DOUBLE CONTAINMENT CAN COMPONENTS

D	DRIVE MAGNET ASSY	1	49704	STEEL	49704	STEEL	49704	STEEL	32
	CAN ASSY, CONTAINMENT	1	49698	316 SS	49699	ALLOY C	49700	ALLOY 20	27
	# O RING, CONTAINMENT CAN	*1	W210422-TFE	TFE	W210422-TFE	TFE	W210422-TFE	TFE	25
	NIPPLE, 1/8" NPT X 2.00	2	W773965-208	316 SS	W773965-235	ALLOY C	W773965-145	ALLOY 20	66

100L FRAME COMPONENTS

COMMON PARTS	HOLDER, DRIVE MAGNET	1	49718	STEEL	49718	STEEL	49718	STEEL	30
	ADAPTOR, MOTOR	1	Y1101000-ALU	ALUMINUM	Y1101000-ALU	ALUMINUM	Y1101000-ALU	ALUMINUM	36
	BOLT, MOTOR (METRIC)	4	W770533-188	188 SS	W770533-188	188 SS	W770533-188	188 SS	41

SINGLE CONTAINMENT CAN COMPONENTS

P	DRIVE MAGNET ASSY	1	49702	STEEL	49702	STEEL	49702	STEEL	31
	RING, CONTAINMENT CAN	1	49719	316 SS	49719	316 SS	49719	316 SS	28

DOUBLE CONTAINMENT CAN COMPONENTS

Q	DRIVE MAGNET ASSY	1	49704	STEEL	49704	STEEL	49704	STEEL	32
	CAN ASSY, CONTAINMENT	1	49698	316 SS	49699	ALLOY C	49700	ALLOY 20	27
	# O RING, CONTAINMENT CAN	*1	W210422-TFE	TFE	W210422-TFE	TFE	W210422-TFE	TFE	25
	NIPPLE, 1/8" NPT X 2.00	2	W773965-208	316 SS	W773965-235	ALLOY C	W773965-145	ALLOY 20	66

*COMPONENT QUANTITY MAY BE CUMULATIVE OVER ENTIRE B / M

DWG: GMH6P202

DENOTES RECOMMENDED SPARE PART

ISOCHEM GMH6 SERIES PUMP CONSOLIDATED B / M

SECTION: MODEL GMH6
PAGE: 203
DATE REV.: 11 / 12 / 12
SUPERSEDES: 02 / 12 / 01

		STANDARD PUMP MATERIAL							
		316 SS (A, K, OR U)		ALLOY C (C, M, OR V)		ALLOY 20 (D, N, OR W)			
DESCRIPTION	QTY	PART NUMBER	MATERIAL	PART NUMBER	MATERIAL	PART NUMBER	MATERIAL	ITEM	

POSITION 8 MAGNETIC COUPLING COMPONENTS

COMMON PARTS	DRIVEN MAGNET ASSY	1	49697	316 SS	49707	ALLOY C	49708	ALLOY 20	24
	BOLT, FRONT HOUSING/ADAPTOR	8	W770407-188	188 SS	W770407-188	188 SS	W770407-188	188 SS	22
	# O RING, CONTAINMENT CAN	*1	W210422-TFE	TFE	W210422-TFE	TFE	W210422-TFE	TFE	25
	PIN, DRIVE MAGNET/HOLDER	2	W771209-003	STEEL	W771209-003	STEEL	W771209-003	STEEL	34
	SCREW, SKHD DRIVE MAGNET/HOLDER	4	W770027-188	188 SS	W770027-188	188 SS	W770027-188	188 SS	33
	CAN, CONTAINMENT	1	49674	ALLOY C	49674	ALLOY C	49674	ALLOY C	26
	SCREW, CONTAINMENT CAN RING	8	W770021-188	188 SS	W770021-188	188 SS	W770021-188	188 SS	29

182/4TC FRAME COMPONENTS

COMMON PARTS	HOLDER, DRIVE MAGNET	1	49757	IRON	49757	IRON	49757	IRON	30
	ADAPTOR, MOTOR	1	Y1100700-ALU	ALUMINUM	Y1100700-ALU	ALUMINUM	Y1100700-ALU	ALUMINUM	36
	SCREW, MOTOR	4	W770580-STL	STEEL	W770580-STL	STEEL	W770580-STL	STEEL	69
	ADAPTOR, PLATE	1	Y1101600-STL	STEEL	Y1101600-STL	STEEL	Y1101600-STL	STEEL	68
	BOLT, ADAPTOR PLATE	4	W770425-188	188 SS	W770425-188	188 SS	W770425-188	188 SS	41
	WASHER, LOCK	4	W771108-188	188 SS	W771108-188	188 SS	W771108-188	188 SS	67
	SCREW, SET	2	W771004-030	STEEL	W771004-030	STEEL	W771004-030	STEEL	35

SINGLE CONTAINMENT CAN COMPONENTS

R	DRIVE MAGNET ASSY	1	49702	STEEL	49702	STEEL	49702	STEEL	31
	RING, CONTAINMENT CAN	1	49719	316 SS	49719	316 SS	49719	316 SS	28

DOUBLE CONTAINMENT CAN COMPONENTS

T	DRIVE MAGNET ASSY	1	49704	STEEL	49704	STEEL	49704	STEEL	32
	CAN ASSY, CONTAINMENT	1	49698	316 SS	49699	ALLOY C	49700	ALLOY 20	27
	# O RING, CONTAINMENT CAN	*1	W210422-TFE	TFE	W210422-TFE	TFE	W210422-TFE	TFE	25
	NIPPLE, 1/8" NPT X 2.00	2	W773965-208	316 SS	W773965-235	ALLOY C	W773965-145	ALLOY 20	66

213/5TC FRAME COMPONENTS

COMMON PARTS	HOLDER, DRIVE MAGNET	1	49758	IRON	49758	IRON	49758	IRON	30
	ADAPTOR, MOTOR	1	Y1100700-ALU	ALUMINUM	Y1100700-ALU	ALUMINUM	Y1100700-ALU	ALUMINUM	36
	SCREW, MOTOR	4	W770068-188	188 SS	W770068-188	188 SS	W770068-188	188 SS	69
	ADAPTOR, PLATE	1	Y1101700-STL	STEEL	Y1101700-STL	STEEL	Y1101700-STL	STEEL	68
	BOLT, ADAPTOR PLATE	4	W770426-188	188 SS	W770426-188	188 SS	W770426-188	188 SS	41
	SCREW, SET	2	W771004-046	STEEL	W771004-046	STEEL	W771004-046	STEEL	35

SINGLE CONTAINMENT CAN COMPONENTS

W	DRIVE MAGNET ASSY	1	49702	STEEL	49702	STEEL	49702	STEEL	31
	RING, CONTAINMENT CAN	1	49719	316 SS	49719	316 SS	49719	316 SS	28

DOUBLE CONTAINMENT CAN COMPONENTS

Y	DRIVE MAGNET ASSY	1	49704	STEEL	49704	STEEL	49704	STEEL	32
	CAN ASSY, CONTAINMENT	1	49698	316 SS	49699	ALLOY C	49700	ALLOY 20	27
	# O RING, CONTAINMENT CAN	*1	W210422-TFE	TFE	W210422-TFE	TFE	W210422-TFE	TFE	25
	NIPPLE, 1/8" NPT X 2.00	2	W773965-208	316 SS	W773965-235	ALLOY C	W773965-145	ALLOY 20	66

*COMPONENT QUANTITY MAY BE CUMULATIVE OVER ENTIRE B / M
DENOTES RECOMMENDED SPARE PART

DWG: GMH6P203