

INPUTS

- Stand-by mode input
- Water meter pulse input
- 0/4-20mA or 0-10 VDC input
- External contact for remote start
- Low tank level with alarm and warning indicator

OUTPUTS

- 4-20mA output
- Alarm relay (Selectable alarms)

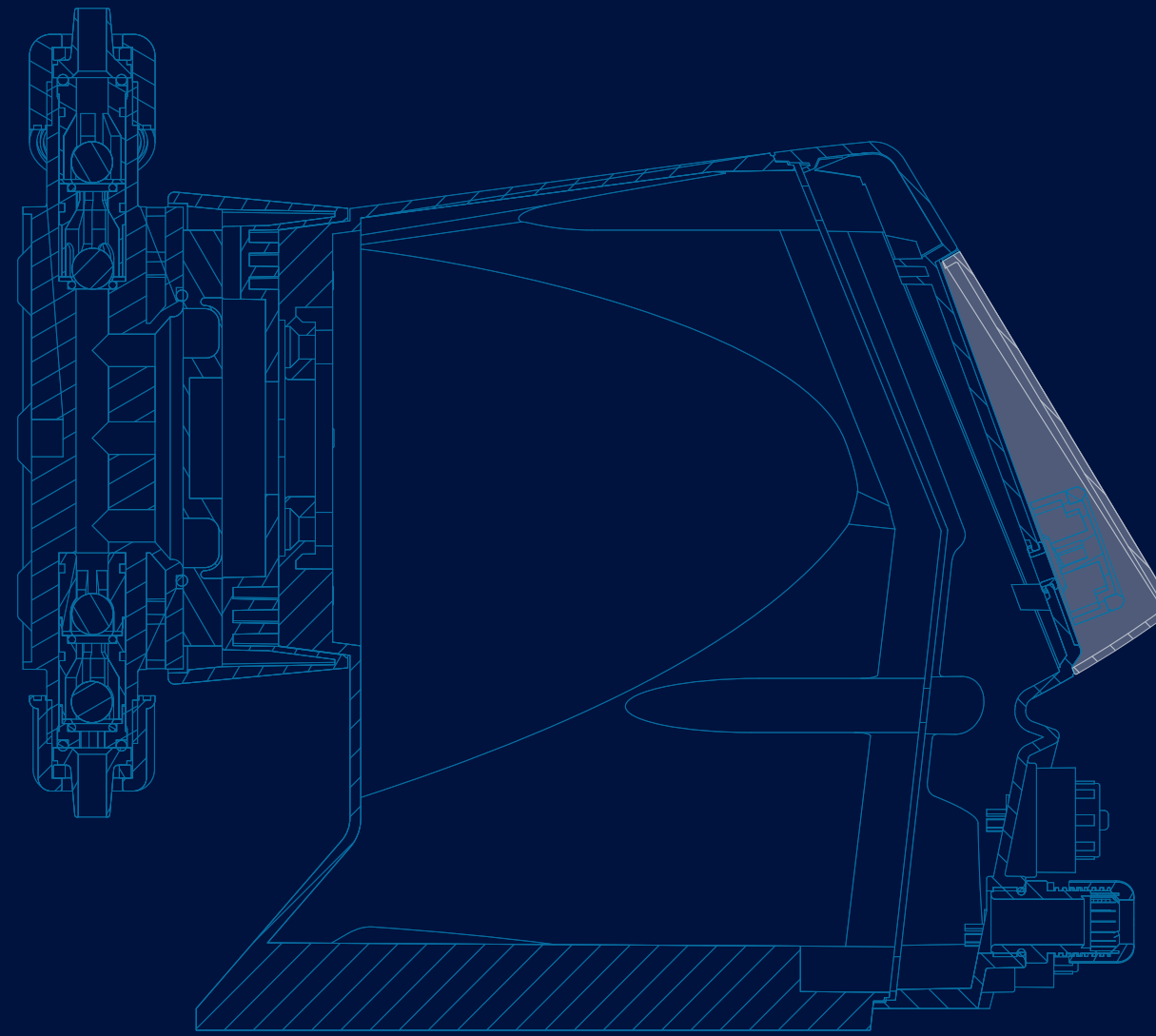

PULSAFEEDER

NEXTSTEP

NXB001 F24



Pulsafeeder, Inc.
27101 Airport Rd, Punta Gorda, FL 33982
T: 800 333 6677 / 941 575 3800
www.pulsafeeder.com



AN ISO 9001 CERTIFIED COMPANY



The NextStep in dosing pump solutions

NextStep dosing pumps are designed for high-resolution metering control and reliability and cover a wide range of applications. The advanced microprocessor-driven stepper motor allows for digital control of both the discharge stroke and the suction stroke duration evenly distributing the chemical into the process. This wide range of control and reduced pulsation allows for reliable metering of off-gassing and viscous chemicals with extremely high accuracy. NextStep pumps are even backed by a five-year warranty that includes the diaphragm.

Programming is simplified using a dial knob interface and intuitive symbols and prompts. A large easy-to-read, multi-color backlit display indicates pump status with four different backlight colors. The **NextStep** communications options keep your process running smoothly even from a remote location.

NextStep also boasts complete control over dosing speeds and multiple operating modes to choose from, the operator can precisely set the flow rate required, meeting even extremely complex applications, and easily read it directly in GPH, LPH, and % on the graphic display.

INTERFACE



MODBUS



RS-485

OPERATING MODES

- Proportional control
 - by a 0/4-20mA input or 0-10 VDC signal
 - by pulse input, controlled based on PPM setpoint, % setpoint or Oz/Pulse, or the flow rate of the pump in GPH/LPH
- Constant output mode
- Daily and weekly timer
- Start-pause control based on a cycle time
- Dry contact input for remote start or stop
- Batch control by dry contact signal or manual activation

TURNDOWN



The **NextStep** diaphragm metering pump is designed for applications requiring high-precision metering volumes and repeatability. The advanced microprocessor-driven stepper motor has a **3,333:1** turndown ratio, and the discharge stroke and suction stroke duration are digitally controlled. The steps are split up into a maximum of **4800 steps** to provide precise distribution of chemical throughout the full range.

SLOW MODE



NextStep metering pumps give you the most accurate control over metering output, providing capacity control from **100% to 0.1%** and suction stroke control from **100% to 30%**. This **Slow Mode** feature increases the reliability of metering off-gassing and high-viscosity chemicals.

CAPACITY RANGE

NextStep has models with flow range from 0.5 gallon per hour to 21.1 gallon per hour and pressures up to 362 psi.

0.5 gph	1.3 gph	2 gph	3.4 gph
362 psi	290 psi	232 psi	145 psi
2 l/h	5 l/h	8 l/h	13 l/h
25 bar	20 bar	16 bar	10 bar

INFO COLOR SCREEN

REAL-TIME FLOW

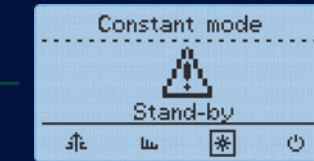

STAND-BY
White



WARNING
Yellow



ALARM
Red

NextStep metering pump is equipped with a dial knob adjustment for quick and easy menu navigation, as well as a large easy-to-read display for convenient setting of the operating parameters and monitoring of the pump's working status.

The multi-function software allows the operator to precisely set the flow rate required by the application. This allows you to enter the desired value and read it directly in GPH, mLPH, LPH and % via the graphic display. All operating modes are displayed clearly and easily through intuitive symbols and prompts.

5.3 gph	7.4 gph	13.2 gph	18.4 gph	21.1 gph
101 psi	72 psi	58 psi	43 psi	29 psi
20 l/h	28 l/h	50 l/h	70 l/h	80 l/h
7 bar	5 bar	4 bar	3 bar	2 bar