

PulsaPro®

HYDRAULIC DIAPHRAGM METERING PUMPS

PP680, PP880, PP7120



Installation, Operation & Maintenance Manual

Bulletin: IOM-PRO-001 Rev C



PULSAFEEDER FACTORY SERVICE POLICY

Should you experience a problem with your *PulsaPro* pump, consult the troubleshooting guide in your operation and maintenance manual. If the issue is not covered or cannot be solved, contact your local Pulsafeeder Sales Representative, or our Aftermarket Department for further assistance.

Trained technicians are available to diagnose your problem and arrange a solution. Solutions may include replacement parts or returning the unit to the factory for inspection and repair. In some cases, onsite support may be needed to rectify the issue.

All returns require Return Authorization Number (RMA) to be issued by Pulsafeeder. In order to make a warranty return efficient and effective, please contact Pulsafeeder's Aftermarket team at proservice@idexcorp.com or by calling (585) 292-8000.

Have the following information available when you contact Service:

- Pump Serial Number and/or Sales Order Number
- Liquid being pumped, preferably Safety Data Sheet (SDS)
- Return Address
- Contact Name and Phone Number
- Reason for Return

TRADEMARKS

PulsaPro® is a registered trademark of Pulsafeeder, Inc. Pulsafeeder® is a registered trademark of Pulsafeeder, Inc.

SAFETY CONSIDERATIONS

- Read and understand all related instructions and documentation before attempting to install or maintain this equipment
- Observe all special instructions, notes, and cautions.
- Act with care and exercise good common sense and judgment during all installation, adjustment, and maintenance procedures.
- Ensure that all safety and work procedures and standards that are applicable to your company and facility are followed during the installation, maintenance, and operation of this equipment.

Copyright ©2017 / 2020 Pulsafeeder, Inc. All rights reserved.

Information in this document is subject to change without notice. No part of this publication may be reproduced, stored in a retrieval system or transmitted in any form or any means electronic or mechanical, including photocopying and recording for any purpose other than the purchaser's personal use without the written permission of Pulsafeeder, Inc.

CONVENTIONS



A WARNING DEFINES A CONDITION THAT COULD CAUSE DAMAGE TO BOTH THE EQUIPMENT AND THE PERSONNEL OPERATING IT. PAY CLOSE ATTENTION TO ANY WARNING.



NOTES ARE GENERAL INFORMATION MEANT TO MAKE OPERATING THE EQUIPMENT EASIER.

Revision History

Revision #	Implemented By:	Revision Date	Approved By	Approval Date	Reason
0.0	M. Groth	NEW	B. Montagno	5/23/2017	New Product Line
1.0	B. Montagno	7/31/2018	M. Lawton	8/01/2018	Drive Train Warranty Added
1.1	E. VanBork	10/23/2018	B. Montagno	10/23/2018	Updated Stroke Lock
1.2	S. Farley	8/13/2020	H. Marahajh E. VanBork	9/03/2020	Updated Pictures Updated Priming Procedures
Rev A	S. Farley	5/26/2021	H. Marahajh	5/26/2021	Updated Leak Detection Section
Rev B	K. Lenzi	10/30/2024	K. Lenzi	10/30/2024	In Section 5.4, changed discharge pressure must exceed suction pressure by at least 5 PSI. Previously stated 20 PSI.
Rev C	S. Farley	01/12/2026	K.Lenzi	01/12/2026	General Updates, added information for PP V2.0

Table of Contents

Pulsafeeder Factory Service Policy.....	1
Trademarks.....	1
Safety Considerations.....	1
1. Introduction	6
1.1 Receiving Inspection.....	6
1.2 General Information.....	6
1.3 Personnel Responsible for Pump Operation.....	6
1.4 Testing.....	6
1.5 Warranty.....	7
1.6 Requesting Spare Parts.....	7
1.7 Spare Parts.....	8
1.8 Liability Exclusion.....	8
1.9 Restrictions Regarding this document.....	8
2. Transport and Storage	8
2.1 Consignment receipt and unpacking.....	8
2.2 Handling.....	8
3. Storage Instructions	9
3.1 Short Term.....	9
3.2 Long Term.....	9
4. Principles of Operation	10
4.1 Overall Operation.....	10
4.2 Nameplate Identification.....	11
4.3 Flow Rate.....	11
4.4 Intended Use.....	11
4.5 Components and Operation.....	12
5. Installation	17
5.1 Location.....	17
5.2 Ideal Metering Pump Installation.....	17
5.3 Suction Pressure Requirements.....	18
5.4 Discharge Pressure Requirements.....	19
5.5 PULSAlarm Leak Detection Electrical Connections.....	19
6. Equipment Setup	20
6.1 Hydraulic Oil Fill.....	20
6.2 Drive Motor Installation.....	21
6.3 Drive Motor Wiring.....	22
6.4 Motor Rotation.....	22
7. Startup Procedure	22
7.1 Output Adjustment.....	22
7.2 Suction System.....	23
7.3 Priming the Pump Head.....	23
7.4 Priming the Reagent Head.....	23
7.5 Calibration.....	23
8. Maintenance	24
8.1 Operating Precautions.....	25
8.2 Consulting with Technical Documentation.....	25
8.3 Oil Changes.....	25
8.4 Wet End Removal, Inspection, and Reinstallation.....	25

8.5 Priming.....	29
8.6 Check Valves.....	31
8.7 Hydraulic Performance Valve (HPV).....	33
8.8 Hydraulic Bypass Valve (HBV).....	34
8.9 Push to Purge (PTP).....	35
8.10 Piston Seals.....	36
8.11 Oil Seal.....	38
8.12 Pump Motor Removal and Reinstallation.....	39
9. Troubleshooting	40
10. Technical Service Support	42
10.1 Authorized Service Centers.....	42
10.2 Local Sales Representatives.....	42
10.3 Factory Service Support.....	42
11. APPENDIX I	43
11.1 PULSAlarm Leak Detection System.....	43
11.2 PULSAlarm Leak Detection Diaphragm.....	43
11.3 Priming of Leak Detection Diaphragm.....	47
12. APPENDIX II	49
12.1 Piping Calculations.....	49
12.2 System Back Pressure.....	50
12.3 Nomenclature.....	50
13. APPENDIX III	51
13.1 Oil Specification.....	51
14. APPENDIX IV	52
14.1 Bolt Torque Recommendations.....	52
15. APPENDIX V	55
15.1 Pulsatrol Pulsation Dampener.....	55
15.2 Back Pressure Valve.....	56
15.3 Pressure Relief Valve.....	56

1. Introduction



THIS DOCUMENT CONTAINS INFORMATION TO BE USED BY QUALIFIED PERSONNEL ONLY

This document covers installation procedures and specifications for two distinct versions of the PulsaPro pump: Version 1.0 and Version 2.0. While both models share core functionality, certain components, configurations, or operational features may differ. Please refer to the relevant sections for details specific to each version to ensure proper installation and setup.

1.1 Receiving Inspection

All materials relative to supply are delivered to the shipper in perfect condition after thorough final testing and packaging. Inspect goods immediately upon receipt and check:

- The goods received correspond to the order made
- The packaging has not undergone damage due to transport or has not been tampered with
- The actual condition of goods

If anomalies or damage are found immediately issue a complaint with the courier and inform Pulsafeeder Customer Service at propumps@idexcorp.com or call Pulsafeeder at 585-292-8000.

1.2 General Information

The purpose of these instructions is to refer information deemed necessary for understanding as much as possible about and facilitating the installation, commissioning, use and maintenance of hydraulic diaphragm metering pumps.

1.3 Personnel Responsible for Pump Operation

Anyone operating the pump should have read and understood the instructions set forth within this manual. The employer must instruct all staff on the risks of accidents and on devices and clothing to be used for individual safety.

1.4 Testing

Each Pulsafeeder metering pump is a reliable quality product, subject to careful final inspection to ensure their proper functioning and found compliance with the specified performance. The final test results, if specifically requested by contract, are registered and made available to the customer. Pulsafeeder offers many different tests available with your PulsaPro pump such as:

- Standard Performance Test (Single Point)
- Three Point Calibration Test
- Hydrostatic Test
- API 675 – Repeatability and Linearity Five Point
- Sound Testing
- And more...

1.5 Warranty

PulsaPro metering pumps are guaranteed for a period of eighteen (18) months from the date of shipment from the factory. Drive assemblies (gearing, shafts, eccentric, and related components within gearbox) are guaranteed for a period of sixty (60) months from the date of shipment from the factory. The guarantee covers replacement, free of charge, of any component found to be defective in material or processing by the Aftermarket Service Group at Pulsafeeder, Inc.

Determination of warranty coverage is solely at Pulsafeeder's discretion and is based exclusively upon our defect evaluation. All obligations and liabilities under this warranty are limited to repair, replacing, or refunding up to the original purchase price. Pulsafeeder shall not be held responsible for any removal or replacement costs, or any additional consequential damages.

Proper maintenance and operational procedures must be followed while the pumps are operating for the warranty to remain in effect. This includes oil changes, replacement of wearable parts, protection from physical damage, etc. Pulsafeeder brand oil must be used during the warranty period to maintain coverage, and proper oil change intervals must be adhered to.

Any coverage required under this warranty will be provided at the Pulsafeeder factory in Rochester, New York. This warranty does not provide for field labor. This warranty does not cover and "remove and replace" charges. In situation where the customer is willing to provide field labor, Pulsafeeder will, at its discretion, provide parts at no charge for field replacement. Warranty parts sent to the field will be sent on Pulsafeeder's standard Bill & Credit terms. New parts are shipped and invoiced. The suspected parts are returned, and upon warranty determination at the factory, a credit is issued against the original invoice.

The Warranty is does not extend to and specifically excludes the following:

- Damage by corrosion or erosion that is NOT a result of defects in workmanship or materials.
- Normal wear items (diaphragms, piston seals, valve assemblies, etc.).
- Improper maintenance.
- Improper protection during normal operation and/or storage.
- Improper piping by the buyer or any third party.
- Defects caused by misuse, abuse, improper application, deployment or operation.
- Expendable items and damage resulting from unauthorized repair.

The materials of construction offered are recommendations, subject in all cases, to verification and acceptance by the customer. These recommendations are based on previous company experience and best available information and do not constitute guarantees against wear or chemical reaction.

1.6 Requesting Spare Parts

For preventative maintenance, Pulsafeeder recommends the installation of a KOPkit (**Keep-On-Pumping**), which includes the recommended spare parts needed. The part number for this kit can be located on the pump nameplate as well as the specification data sheet provided with your metering pump.

For other needed components, find and study the sectional drawings of the pump in use, if necessary, contact Pulsafeeder to obtain a copy. For drawings and bill of materials for your pump(s) please send an email to Prodocs@idexcorp.com. Using the nomenclature of the sectional drawing, make a list of the parts needed and send to your local Pulsafeeder sales representative, always specify the pump serial number.

To find the local Pulsafeeder representative for parts pricing and availability log onto www.pulsafeeder.com, select "Sales Contacts". If additional assistance is needed, call Pulsafeeder at 585-292-8000.

1.7 Spare Parts

Modifications are not allowed. Original Pulsafeeder spare parts and accessories are to be used to assure conformity with safety rules. Pulsafeeder declines any responsibility in case of use of non-original parts and which results in the warranty being voided.

1.8 Liability Exclusion

Attempts to disassemble, modify, or tamper in general by unauthorized personnel will void the warranty and will release Pulsafeeder from any liability for damage caused to persons or property resulting from such actions.

Pulsafeeder is considered released from any liability in the following cases:

- Improper Installation
- Improper use of the machine by non-professional or inadequately trained operators
- Use not in compliance with regulations in the Country of use
- Lack of maintenance or improperly performed
- Use of non-original spare parts or incorrect parts for model in question
- Total or partial failure to observe the instructions
- Exception environmental events

1.9 Restrictions Regarding this Document

This document is the property of Pulsafeeder together with the technical information contained in it. Modification, reproduction, or copying (in part or whole) without written permission is prohibited.

2. Transport and Storage

2.1 Consignment receipt and unpacking

Immediately after receipt of the equipment it must be checked against the delivery/shipping documents for its completeness and that there has been no damage in transportation.

Check any crates, boxes, or wrappings for any accessories or spare parts that may be packed separately with the equipment or attached to side walls of the box.

Each product has a unique serial number, check that the number corresponds with that advised, and always quote this number in correspondence as well as when ordering spare parts.

Shortages or damage should be reported immediately to the carrier and your Pulsafeeder Representative.

2.2 Handling

Boxes, crates, pallets, or cartons may be unloaded using forklift vehicles or slings dependent on their size and construction. Slings, ropes, and other lifting gear should be positioned where they cannot slip and where a balanced lift is obtained. If lifting without equipment, follow safe practices to avoid injury (i.e. lifting with two people).

3. Storage Instructions

3.1 Short Term

Storage of PULSAPro pumps for up to twelve (12) months is considered short-term. The recommended short-term storage procedures are:

- Store the pump indoors at room temperature in a dry environment
- Confirm or fill the eccentric box to its normal operating level with PULSAube 6H-GS hydraulic oil. If required by the operating environment, take steps to prevent entry of water or humid air into the eccentric enclosure.
- Prior to startup, inspect the housing and gearbox. Replenish hydraulic oil as required to maintain operating levels. If water or condensation is present, change oil as described under Equipment Set-Up.
- Start up in accordance with instructions in this manual

3.2 Long Term

Every twelve months, in addition to the above short-term procedures, power up the motor and operate the pump for a minimum of one hour. It is not necessary to have liquid in the reagent head during this operation, but the suction and discharge ports must be open to atmosphere. If the pump is equipped with a PULSAlarm leak detection system, ensure that a vacuum is drawn before operating the pump. See Appendix I for more information.

After twelve months of storage, Pulsafeeder Warranty cannot cover such items which are subject to deterioration with age such as seals and gaskets. If the pump has been in storage longer than twelve (12) months, it is recommended that such items be inspected and replaced as necessary prior to startup. Materials and labor to replace this class of items under these circumstances are the purchaser's responsibility. For continuance of the warranty after extended storage, equipment inspection and any required refurbishing must be done by a Pulsafeeder Representative.

4. Principles of Operation

4.1 Overall Operation

A piston reciprocates within an accurately sized cylinder at a preset stroke length, displacing an exact volume of fluid. The piston, however, does not pump various chemicals. The piston and associated mechanisms are enclosed in a gearbox that also serves as a hydraulic oil reservoir. A diaphragm separates the oil from the product pumped. The diaphragm moves in exact response to piston displacement. The diaphragm does no work and acts only as a separator. Consequently, the oil displacement is translated into equal product displacement. The piston retraction causes the product to enter through the suction check valve. Piston advancement causes the discharge of an equal amount of product through the discharge check valve.

Individual pumps may vary in appearance due to various liquid ends, accessories, and multiplexing. The basic principles of operation, however, remain the same.

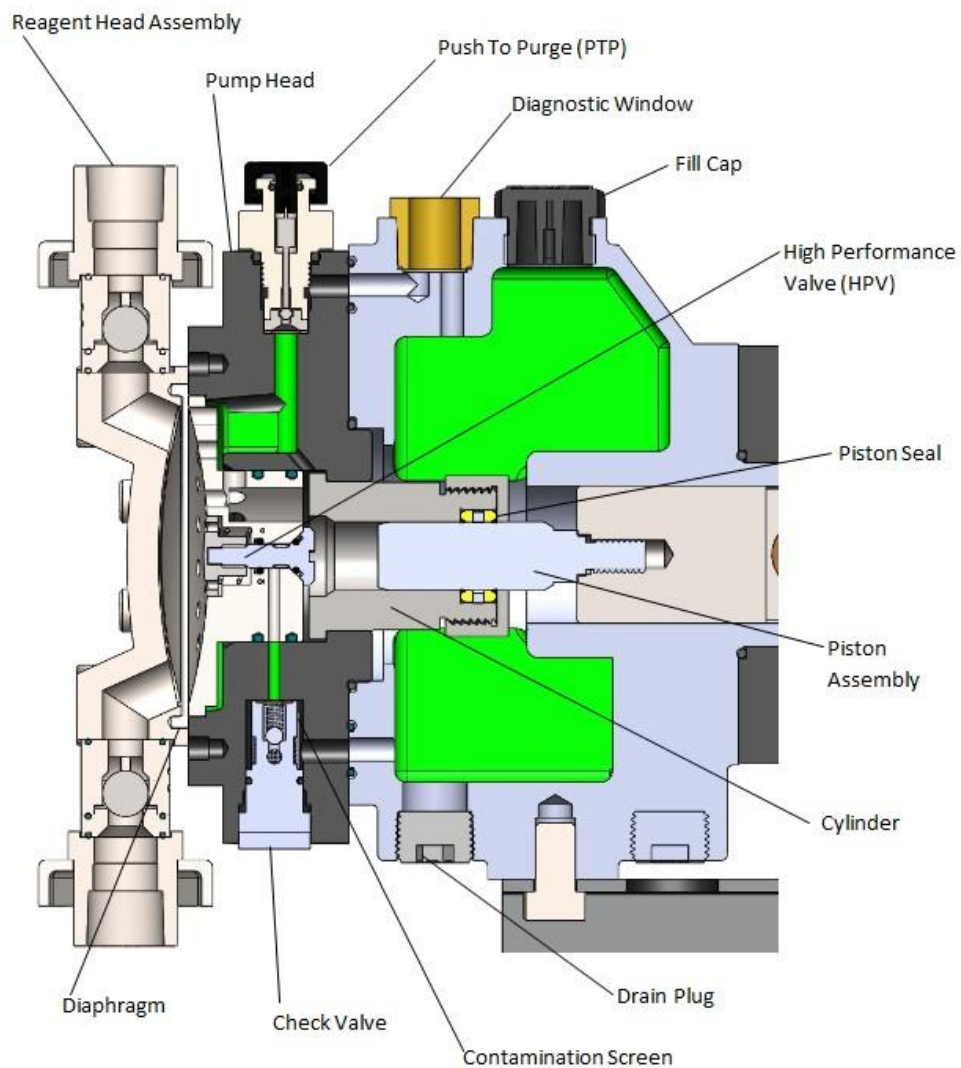

Figure 1

4.2 Nameplate Identification

Each pump carries a nameplate for identification with the following information:

- Model Series
- Serial Number
- Rated Flow
- Rated Pressure
- KOPkit (recommended spare parts)
- Piston Diameter
- Gear Ration
- Motor Frame Size, RPM Rating



Figure 2

4.3 Flow Rate

PulsaPro has pulsating flow rates, generated by the alternating movement of the piston and the action of the check valves on the pump head which determine flow direction. Pump flow rate is adjustable and increases or decreases in direct proportion to the variation of the stroke adjustment.

The theoretical flow rate – corresponds exactly to the volume described by the movement of the diaphragm.

The actual flow rate – is inevitably lower than the theoretical flow rate, due to the volumetric efficiency of the pump. It varies depending on the type and size of the pump, the nature and viscosity of the liquid to be pumped, working pressure, etc.

4.4 Intended Use

PulsaPro 680, 880, and 7120 pumps are designed for dosing liquid fluids (flammable, acids, alkaline, solvents, etc.) at ambient temperature or heated, suitable for continuous service.

These pumps are used in the following markets:

- Chemical Processing, Petrochemical, Oil & Gas, Power & Energy, Water/Wastewater treatments, and General Industries.

Applications may include but not limited to:

- Amines, Defoamers, Oxygen Scavengers, Disinfectants, Oil Additives, Acids, Demulsifiers, Caustics, Methanol, Biocides, Corrosion Inhibitors, Ethylene Glycol, Anti-Scalants, and other chemical feeds.

4.5 Components and Operation

Reagent Head (Wet End) – the typical reagent head assembly consists of the reagent head, diaphragm, and the suction/discharge check valves. This assembly is the only part of the pump to contact the process liquid; consequently, maintenance is critical to pump performance.

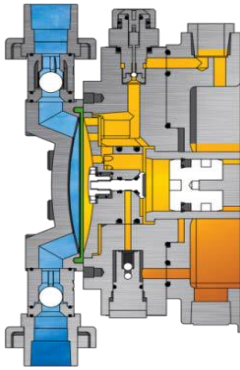

Figure 3

Types of Diaphragms – the PulsaPro 680, 880, and 7120 offer the Flat Diaphragm, HYDRAtube, and HYDRAcone. Additionally, you can utilize our Double Diaphragm (Flat) with PULSAlarm Leak detection. (Figure 4 showing the Flat diaphragm, HYDRAtube, and HYDRAcone)

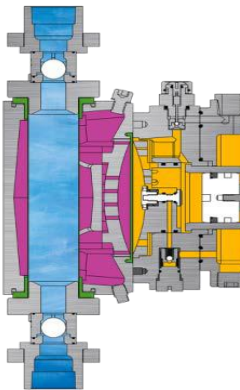

Figure 4



Flat Diaphragm – is the standard design ensuring high performance metering in a leak-free operation. Pulsapro flat diaphragms are available in a variety of both metal and plastic materials and can handle a wide range of chemicals. As with Pulsapro diaphragm constructions, the flat diaphragm is hydraulically balanced and operates stress free, providing exceptional life and accuracy.

Figure 5



HYDRAtube – is the best choice for sheer sensitive, high viscosity fluids and slurries. It's straight flow through design eliminates clogging and flow restrictions. It offers double diaphragm safety as a standard as well as optional slurry valves. Available in FKM, CSM, or PFA, it can be utilized with the most corrosive or acidic chemicals. Optional ChemAlarm leak detection system monitors the electrical conductivity of the intermediate liquid between the HYDRAtube and second diaphragm to detect diaphragm failure and, can signal an alarm or stop the pump.

Figure 6

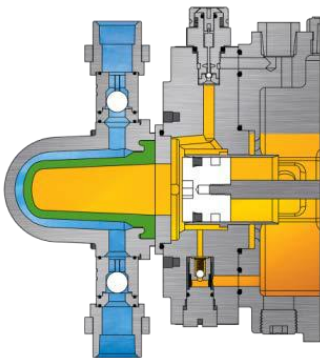

HYDRAcone – self priming head features a conical elastomer diaphragm. It is particularly well suited for high-lift conditions, high viscosities, and low-density slurries. It has a straight, flow through design and option slurry valves. The HYDRAcone is available in high performance fluorocarbon elastomers.

Figure 7

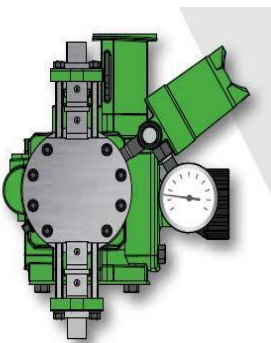

Double Diaphragm (Flat) with PULSAlarm Leak Detection – offers a rugged sandwich style double diaphragm construction for increased protection against leaks. PULSAlarm provides a pressurized leak detection technology to monitor the diaphragm integrity and can signal an alarm or stop the pump at the first sign of diaphragm failure. PULSAlarm is designed to contain full rated pressure up to 3,000 PSI (207 BAR), and is rated NEMA Type 7, EEMAC7 Class 1, Division 1, Groups C&D, Class 1, Zone 1, Groups IIA&IIB; UL, cUL, CE, ATEX. An optional pressure gauge is also available for visual indication of diaphragm integrity at the pump.

Figure 8

Pump Head Assembly – attached to the intermediate head of the pump, it consists of the pump head, cylinder, piston assembly, and three hydraulic valves.

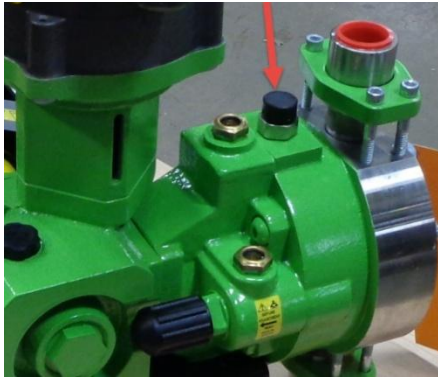

Push-To-Purge (PTP) – situated at the top of the pump head automatically removes gases from the hydraulic system during normal operation. Momentary manual actuation of the external valve button overrides automatic operation to validate priming or to determine diaphragm integrity.

Figure 9

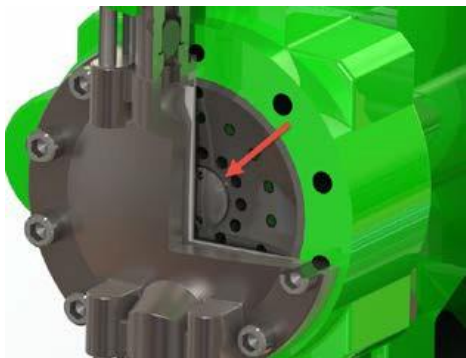

Hydraulic Performance Valve (HPV) – integrated within the dish plate this valve automatically maintains the required hydraulic oil volume by replacing any oil lost past the piston or through the PTP valve.

Figure 10

Hydraulic Bypass Valve (HBV) – this valve protects the pump from over-pressurization by relieving any excess pressure in the pump’s hydraulic system. The valve is preset based on customer’s specification, typically adjusted to 10% above the system pressure. The sight glass above the valve allows visual aid to observe the operation. Refer to Figure 11A.

For *PulsaPro Version 2.0*, the HBV will be located in a different orientation on the pump head, as shown in Figure 11B. There will no longer be a sight glass above the valve, rather a diagnostic window located on the intermediate head.

 **Designed to protect the pump only, does not provide an overall system protection.**



Figure 11A

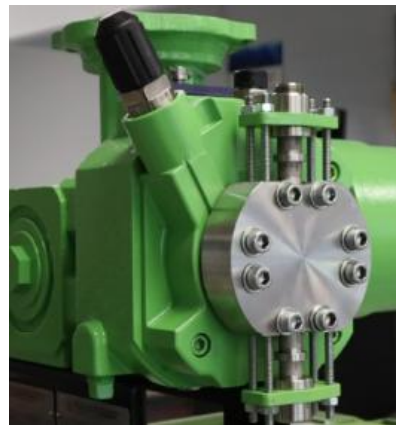

Figure 11B

Manual Control/Stroke Adjustment

The PulsaPro pump flow rate is adjusted by changing the stroke length on a scale from 0 – 100%. The stroke is adjusted by turning the control knob to the desired setting. The stroke length percentage is denoted by a scale located at the top of the hand wheel. There is a locking screw that is used to lock the stroke setting.



THE LOCKING SCREW MUST BE USED TO MAINTAIN THE STROKE SETPOINT. FAILURE TO DO SO MAY RESULT IN DRIFTING OF SETPOINT DURING OPERATION.



Figure 12

Automatic Stroke Adjustment

If ordered with a controller you would have the XAE which is a microprocessor-based stroke length control device. The unit is physically attached and integrated into the pumps design. This controller allows for precise adjustment of output flow of a process media by means of stroke length position. For additional information on your XAE please download or review a copy of the IOM.

For **PulsaPro 2.0**, the XAE will be mounted with a more robust XAE Adaptor, as shown in Figure 13B.



Figure 13A

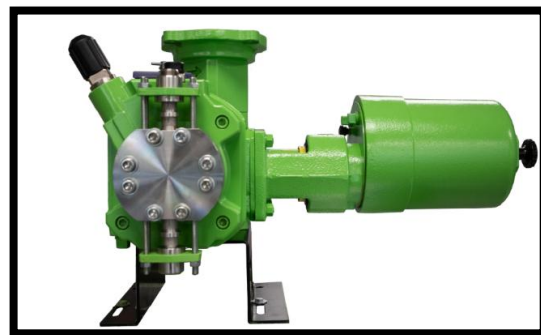

Figure 13B

Gear Ratio Assembly/Motor Adaptor

PulsaPro pumps are driven by a standard C-face electric motor mounted on the adaptor input flange. The motor drives a set of worm gears located in the gearbox which will then convert rotational speed into torque. They in turn power the eccentric shaft assembly that converts rotary motion into reciprocating motion. The motor adaptor is available in a variety of sizes to accommodate different motor frame specifications. The motor adaptor may be equipped with two slots or a NPT plug.



Figure 14A (PulsaPro V. 1.0)



Figure 14B (PulsaPro V. 2.0)

More than one pump can be driven through a single drive assembly, which is referred to as multiplexing. The pumps are mounted on a common gear reducer assembly on the drive pump and the pump without a gear reducer is called the driven pump. Each pump is mounted on its respective standard simplex base. Each pump will have its own gear ratio.

Whenever pumps are multiplexed, the eccentric shafts are positioned to place a uniform load on the driver. Before full disassembly, always note the relative positions of the eccentric shafts to each other so they can reassemble in the same orientation.



Figure 15

5. Installation

5.1 Location

When selecting an installation site or designing a skid package, consideration should be given to access for routine maintenance.

PulsaPro pumps are designed to operate indoors and outdoors, but it is desirable to provide a hood or covering for outdoor service. External heating may be required if ambient temperatures are below -40°F are anticipated. Check with the factory regarding suitability of the operating environment.

The pump must be rigidly bolted to a solid and flat foundation to minimize vibration, which can loosen connections. When the pump is bolted down, care must be taken to avoid distorting the base and affecting alignments, check for levelness when securing. This will assure that the hydraulic oil is maintained at the proper levels and that the check valves can operate properly.

5.2 Ideal Metering Pump Installation

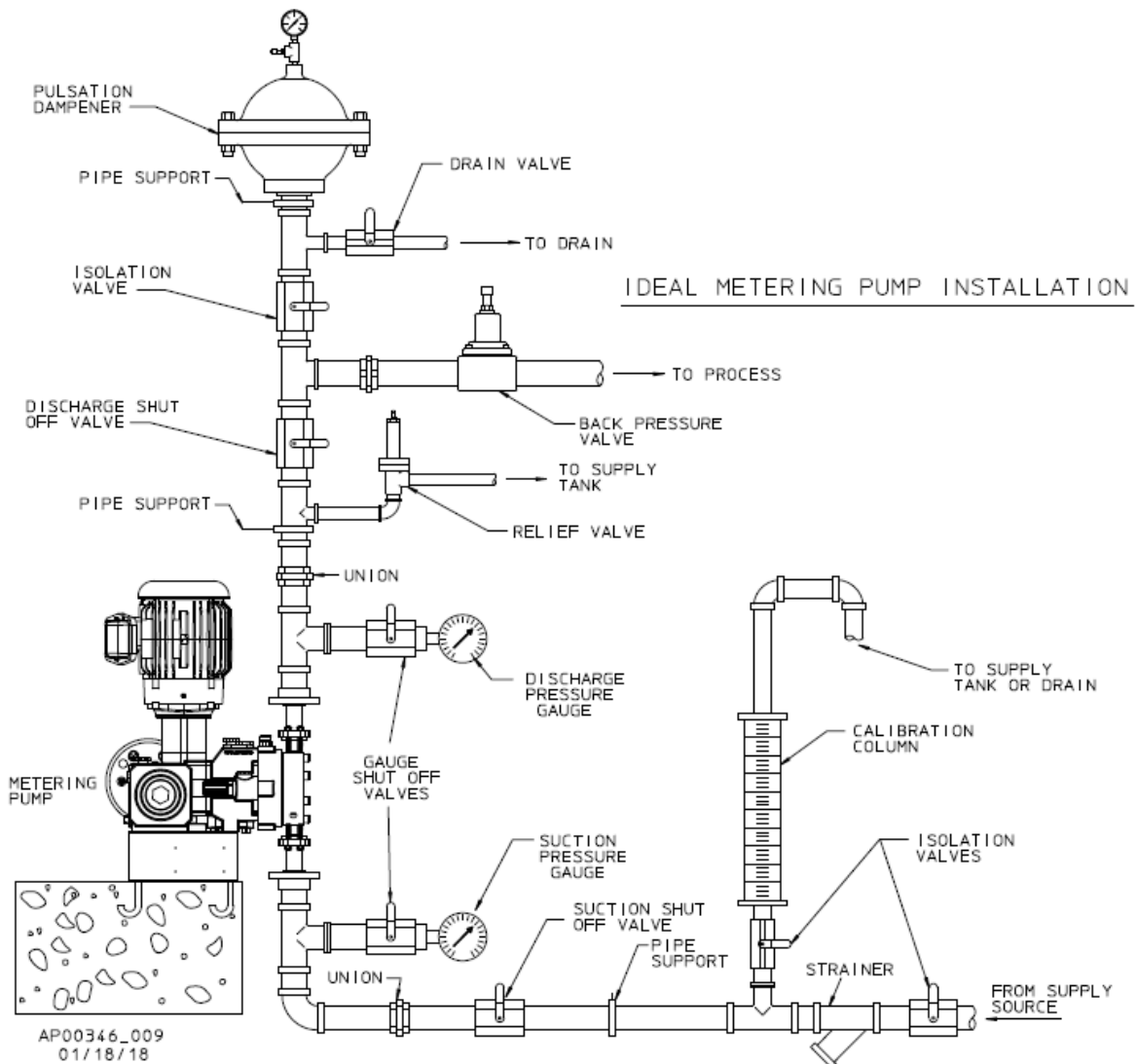

Figure 16

All piping systems should include:

- Shutoff valves and unions (or flanges) on suction and discharge piping. This permits check valve inspection without draining long runs of piping. Shutoff valves should be the same size as connecting pipe. Ball valves are preferred since they offer minimum flow restriction.
- An inlet strainer, if the product is not a slurry. Pump check valves are susceptible to dirt and other solid contaminants unless designed for that service, and any accumulation can cause a malfunction. The strainer should be located between the suction shutoff valve and the pump suction valve. It must be sized to accommodate the flow rate and the anticipated level of contamination; 100 mesh screens are recommended.
- Vacuum/pressure gauges in the suction and discharge lines installed to check system operation. Gauges should be fitted with protective shutoff valves for isolation while not in use.
- A separate system relief valve to protect piping and process equipment, including the pump, from excess process pressures.

Piping weight must not be supported by the valve housings or other portions of the reagent head, as the resulting stresses can cause leaks. If appropriate, provide for thermal expansion and contraction so that no excess force or moments are applied to the pump.

If piping assembly, use a sealing compound chemically compatible with the process material.

Users of sealing tape are cautioned to ensure that the pipe thread ends are not taped. Both new and existing piping should be cleaned, preferably by flushing with a clean liquid (compatible with process material) and blown out with air, prior to connection to the pump. Flow issues at pump startup are often related to the check valves being fouled with piping and process debris.

5.3 Suction Pressure Requirements

Although Pulsapro metering pumps have suction lift capability, all pump installations should have minimum lift for optimum performance. A flooded suction (i.e., suction pressure higher than atmospheric pressure) is preferable whenever possible. The pump should be located as close as possible to the suction side reservoir or other source.

Piping should be sized to allow for best possible NPIP conditions.



IT IS NOT RECOMMENDED TO INSTALL A PUMP EQUIPPED WITH A PULSALARM LEAK DETECTION IN A SUCTION LIFT SYSTEM

If suction lift is required, the net positive inlet pressure required (NPIPR) is 5 PSI (.35 BAR). If this requirement is not met the process liquid may cavitate inside the pump, degrading metering accuracy. To maintain prime on a suction installation, a foot valve is required. In addition, suction pressure must be maintained at a minimum absolute value of 7 PSI (.48 BAR) to ensure proper hydraulic system and proper pump operation.



IT IS CRITICAL THAT PULSAPRO PUMPS HAVE FREE FLOWING AND UNOBSTRUCTED SUCTION CONDITIONS AT ALL TIMES. CLOSED VALVES, CLOGGED STRAINERS, OBSTRUCTED PIPING, ETC. ARE TO BE AVOIDED. SUCTION RESTRICTIONS CAN PLACE STRESS ON THE DIAPHRAGM THAT MAY RESULT IN PREMATURE FAILURE.

Refer to Appendix II for procedures for the calculation of suction pressure.

5.4 Discharge Pressure Requirements

PulsaPro Metering Pumps are designed for continuous service at the rated discharge pressure. If system suction pressure exceeds system discharge pressure, flow would be generated in addition to that caused by the pump, resulting in a reduction in accuracy and loss of control over the metering process. To prevent this condition, commonly referred to as “flow-through”, discharge pressure must exceed suction pressure by at least 5 PSI (.35 BAR). The installation of a back-pressure valve can achieve this is necessary to achieve the differential pressure.

Discharge systems should be protected from excessive pressures by utilizing a pressure relief or pressure limiting valve in the piping system. Operation of the pump at pressure above its rated maximum (found on nameplate) may result in damage to the pump components and/or unsafe system conditions.

Refer to Appendix II for procedures for the calculation of discharge pressure.

5.5 PULSAlarm Leak Detection Electrical Connections

If equipped with an optional pressure switch, install electrical wiring and conduit in accordance with local electrical codes.

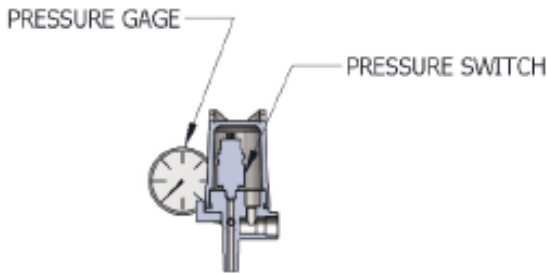

Figure 17

The switch is rated as follows:

Voltage	115VAC
Phase	Single
Load	1.0 Amp (Resistive)
Contacts	NO/NC (SPDT)
Connection	Flying Leads, 20AWG
Max Pressure	3000PSI

The switch is the SPDT (single pole, double throw) type and can therefore be connected to either open or to close upon detection of a diaphragm leak condition. Contacts or wires are identified as follows:

Normally Open (NO)
Normally Closed (NC)
Common (COM)

Wire Color White
Wire Color Red
Wire Color Black

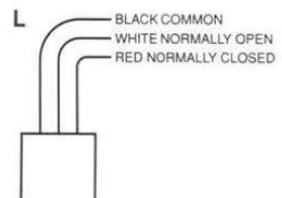

THE ENCLOSURE IS LABELED WITH APPLICABLE SAFETY AGENCY RATINGS FOR HAZARDOUS AREA INSTALLATION. SINCE THE SWITCH IS OF THE MECHANICAL CONTACT TYPE, IT CAN NEVER QUALIFY AS NON-SPARKING (NON-INCENDIVE, OR “M”) FOR OCCASSIONAL AND SHORT-TERM HAZARDOUS AREA USE. PROTECTION MUST BE PROVIDED BY THE ENCLOSURE.

Go to Section 11 Appendix I for further description and instructions for the PULSAlarm Leak Detection System.

6. Equipment Setup

6.1 Hydraulic Oil Fill

The PalsaPro ships from the factory pre-filled with oil after testing is completed. When starting up you can verify the oil level from the provided sight glass on the gearbox as well as the Intermediate Head.



Figure 18



Figure 19



Figure 20

Remove the oil fill cap on the intermediate head and the gearbox to gain access to the reservoir and add PULSAube 6HG hydraulic oil. For the 680/880 models, you will fill the pump head by remove the sight glass next to the PTP valve on the Intermediate head (Figure 19). The 7120 model will have an additional oil fill cap on the intermediate head (Figure 20). High oil level will not affect the operation of the pump; however, it can result in nuisance leakage of oil.

For **PalsaPro V.2.0**, we will be utilizing a diagnostic window, as noted below.

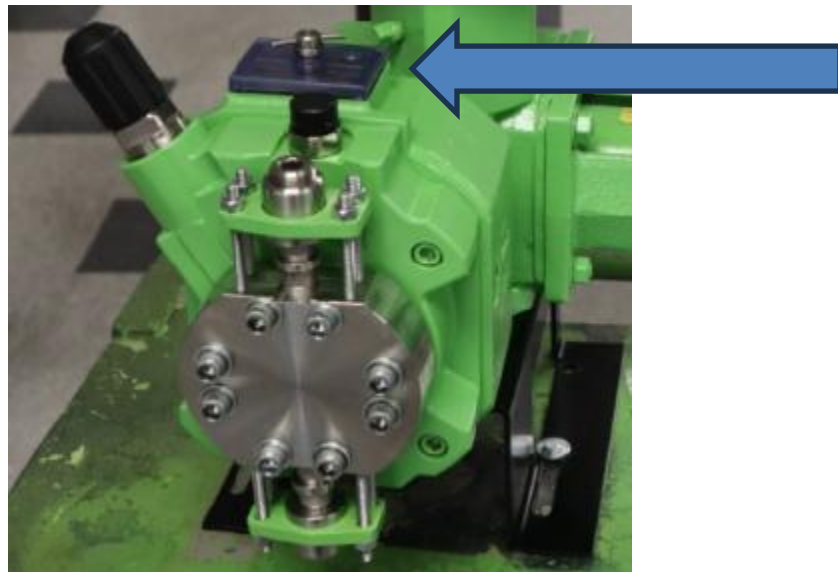

Oil Capacities (Dependent on Piston Size and Internal Components)

MODEL	COLOR	AMOUNT
PP680	Orange	19 – 23 oz.
PP880		
PP7120		39 – 44 oz.

MODEL	COLOR	AMOUNT
PP680 Version 2.0	Orange	23 – 27 oz.
PP880 Version 2.0		
PP7120 Version 2.0		61 – 65 oz.

6.2 Drive Motor Installation

PulsaPro pumps may be shipped with the drive motor packed separately. This is done to avoid damage during transport.

- Remove the unattached coupling half from the motor adaptor. Ensure that the elastomer coupling spider remains in place, on the coupling half that remains attached to the worm shaft in the pump.
- If applicable, remove any tape or retainer rings that hold the motor shaft key in place.
- Place the loose coupling half on the motor shaft. Align the face of the motor shaft flush with the face of the coupling.
- Tighten the setscrew onto the shaft key
- Place the motor in a vertical position and align the coupling teeth
- Install the motor downwards onto the adaptor. Final position can be achieved by slightly rotating the motor until the coupling jaws align
- Rotate the motor until the clearance holes in the adaptor and the tapped holes in the motor align. Fasten the motor to the adaptor using the supplied bolts (4). Tighten bolts evenly to secure motor.

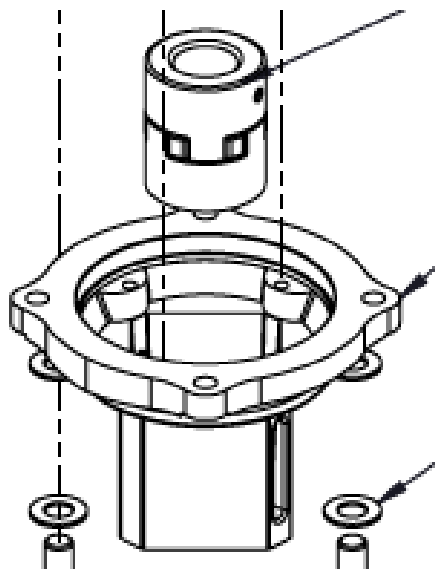

Figure 21

6.3 Drive Motor Wiring

Wire the PulsaPro drive motor according to the motor vendor's nameplates and instructions, and according to any appropriate national and local electrical codes and regulations.

6.4 Motor Rotation

Verification of the motor direction is necessary at startup. The motor direction must be counterclockwise as indicated on the gearbox by a directional arrow.



Figure 22

7. Startup Procedure

7.1 Output Adjustment

All PulsaPro pumps have a hand-knob for manual stroke length adjustment. Mounted on the side of the gearbox, the hand-knob can be adjusted at any point (from 0 to 100% stroke setting) by rotating the hand wheel as required. Stroke length is locked during operation to prevent drifting. Loosen the set screw to adjust the stroke rate and retighten after adjustment. The indicator adjacent to the hand-knob displays the output setting.

Adjustments can be made while the pump is at rest or operating, although operating adjustments are easier to make.



Figure 23



IF THE PUMP IS EQUIPPED WITH A PRESSURE LEAK DETECTION SYSTEM, THE SYSTEM MUST REMAIN SEALED AT ALL TIMES DURING PUMP OPERATION, WHETHER OR NOT LEAK DETECTION IS REQUIRED. IF THE SEAL IS BROKEN, DECREASED FLOW AND/OR DIAPHRAGM DAMAGE WILL OCCUR. SEE APPENDIX I FOR FURTHER INFORMATION

LEAK DETECTION DIAPHRAGM SYSTEMS REQUIRE SPECIAL HYDRAULIC PRIMING CONSIDERATIONS TO PROTECT THE DIAPHRAGM FROM DAMAGE DURING INTIAL PUMP STARTUP. SEE APPENDIX I FOR FURTHER INFORMATION.

7.2 Suction System

Before operation of any PulsaPro pump, carefully ensure that all suction valves are in the open position. Verify that all filters and strainers are clean and clear. Ensure that any other potential causes of restriction have been addressed. Unrestricted flow of liquid to the suction side of the pump is critical to proper operation.

7.3 Priming the Pump Head

All pumps are shipped with a fully primed hydraulic system. However, during shipping and handling some air may enter the hydraulic system. Generally, this air will be automatically purged after a short run-in period. If necessary, rapid purging may be accomplished by fully depressing and holding the PTP valve for five to ten seconds, while the pump is operating. Repeat as necessary until the pump stabilizes at rated flow.

7.4 Priming the Reagent Head

- Open the suction and discharge line shutoff valves
- If the piping system design and the storage tank are such that the product flow due to gravity through the pump, no priming is required. In the event the discharge line contains a significant amount of pressurized air or other gas, it may be necessary to lower the discharge pressure to enable the pump to self-prime.
- If the installation involves a suction lift, it may be necessary to prime the reagent head and suction line. Try priming the reagent headfirst. Remove the discharge valve by unscrewing the four tie bar bolts and removing the valve as a unit. Fill the head through the discharge valve port with process (or compatible) liquid, then reinstall the valve and retighten the tie bar bolts to the recommended specification.
- Start the pump at the 0% stroke length setting and slowly increase the setting to 100% to prime the pump. If this does not work, it will be necessary to fill the suction line.
- Filling of the suction line will necessitate the use of a foot valve or similar device at the end of the suction line so that liquid can be maintained above the reservoir level. Remove the suction valve assembly, fill the line, replace the valve, then remove the discharge valve assembly and fill the reagent head as described in the third step above. The pump will now self-prime when started up per step four above.

7.5 Calibration

All metering pumps must be calibrated to accurately specify stroke length settings for required flow rates.

A typical calibration charge is shown in figure 24. Although output is linear with respect to stroke length setting, an increase in discharge pressure decreases output uniformly, describing a series of parallel lines, one for each pressure (only two are shown).

The theoretical output flow rate at atmospheric output pressure is based on the displacement of the hydraulic piston (the product of piston cross-sectional area and stroke length) and the stroking rate of the pump. With increasing the discharge pressure there is a corresponding decrease in output flow of approximately 1% per 100 PSI (7 BAR) increase in output pressure. Whenever possible, calibration should be performed under actual process conditions (i.e., the same or a similar process liquid at system operating pressure).

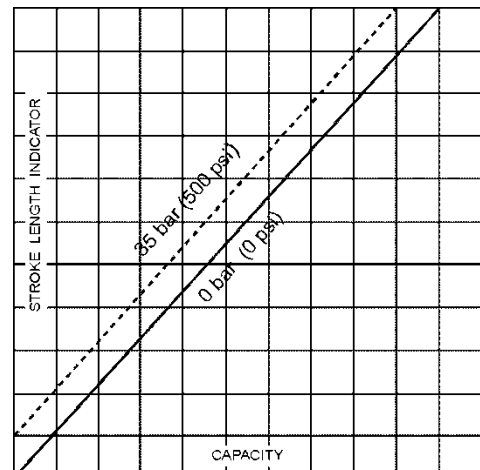

Figure 24

To assure a sound hydraulic system, run the pump for ten to fifteen minutes prior to calibration. This will allow the PTP valve to purge any air from the system.

To construct a calibration chart, measure the flow rate several times at three or more stroke settings (i.e., 25, 50, 75, and 100), plot these values on linear graph paper, and draw a best fit line through the points. For stable conditions, this line should predict settings to attain required outputs. See figure 25 for example of a four-point test plotted onto a calibration chart.

Checking the actual flow rates is especially important in pumps producing low flow rates and operating against high discharge pressures. In this type of system, normal losses of efficiency can result in lack of measurable flow at shorter piston stroke lengths. This is a function of the system conditions and does not indicate a problem with the pump. Careful measurement of actual pump flow at several test points will allow for proper calibration over the complete flow range.

Figure 25
Pump Curve
(4 Point)

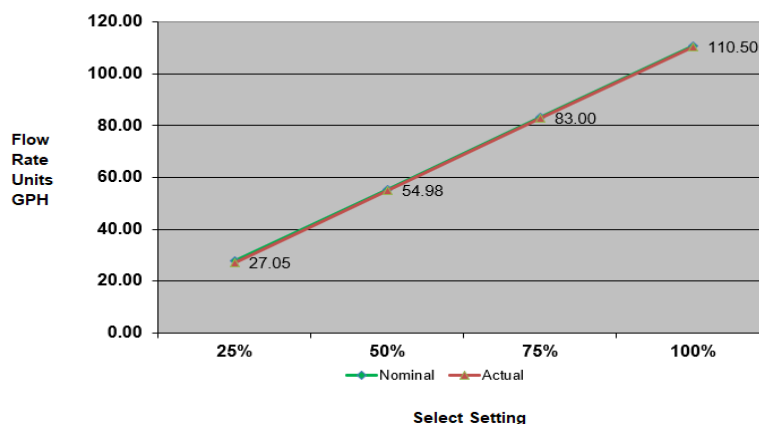

8. Maintenance

Accurate records from early stages of pump operation will indicate the type and levels of required maintenance. A preventative maintenance program based on such records will minimize operational problems. It is not possible to forecast the lives of wetted parts such as diaphragms and check valves. Since corrosion rates and operational conditions affect functional material life, each metering pump must be considered according to its service conditions.

Each PulsaPro pump is provided with an individual specification data sheet included in the parts list package. The data sheet contains important information relating to the application along with the pump serial number and pump specifications (i.e., materials, piston size, stroking rate, etc.).

PulsaPro KOPkits (**Keep-On-Pumping**) contains all the replacement parts normally used in preventative maintenance program. It is always recommended that KOPkits and PULSAube hydraulic oil be kept available. A good instruction manual, parts list, and a good maintenance record are key to long trouble-free metering pump operation.



BEFORE PERFORMING ANY MAINTENANCE REQUIRING REAGENT HEAD OR VALVE (WET END) DISASSEMBLY, BE SURE TO RELIEVE PRESSURE FROM THE PIPING SYSTEM AND, WHERE HAZARDOUS PROCESS MATERIALS ARE INVOLVED, RENDER THE PUMP SAFE TO PERSONNEL AND THE ENVIRONMENT BY CLEANING AND CHEMICALLY NEUTRALIZING AS APPROPRIATE. FOLLOW SAFETY MEASURES BY WEARING YOUR PROTECTIVE CLOTHING BASED ON THE HAZARDOUS.

8.1 Operating Precautions

All operations must be performed by qualified personnel. Prior to work:

- The power line is disconnected, and no parts are energized
- Any risk of accidental restart has been excluded
- Handled fluid, present in the pump head and pipelines is not pressurized
- With the pump off, suction and discharge valves are closed
- Pump has been adequately cleaned, when operating in aggressive chemical environments

THESE MAINTENANCE SUGGESTIONS ARE NOT INTENDED AS “DO IT YOURSELF” REPAIRS. TO PERFORM SUCH WORK, SPECIALIZED TECHNICAL KNOWLEDGE IS REQUIRED, AND OPERATIONS ARE TO BE PERFORMED BY QUALIFIED PERSONNEL.

8.2 Consulting with Technical Documentation

Before starting work, you should consult this maintenance manual, identify the correct sectional drawing of the pump in use and get all the tools and equipment necessary to perform the maintenance or repair work.

When the pump has been disassembled, waiting to be reassembled, it is necessary to protect the various components to prevent damage caused by oxidation or accidental impact.

8.3 Oil Changes

It is recommended after six months of operation to replace the hydraulic oil within the PulsaPro pump. To accomplish this, you will need to remove the drain on the gearbox as well as the drain plug on the intermediate head. Oil changes thereafter would be on an annual basis for Normal Service, or every six months for Severe Service as defined below.

Normal Service: Clean/Dry Atmosphere, an ambient operating temperature of 0°C to 40°C (32°F to 104°F) and/or up to 2,000 annual operating hours.

Severe Service: Humidity/Chemical/Dust laden atmospheres, and/or ambient operating temperatures below 0°C or above 40°C (below 32°F, above 104°F), and/or over 2,000 annual operating hours.

Hydraulic Oil Change Procedure:

- Disconnect the power source to the drive motor
- Relieve all pressure from the piping system
- Drain the oil by removing the drain plug on the gearbox
- Drain the remaining oil in the pump head/intermediate head reservoir by removing the drain plug located on the bottom of the intermediate head
- After drained, replace the plugs using thread sealant
- Fill both the gearbox and intermediate head with PULSAube 6H

8.4 Wet End Removal, Inspection, and Reinstallation



IF THE DIAPHRAGM HAS FAILED, PROCESS MATERIAL MAY HAVE CONTAMINATED THE PUMP HYDRAULIC OIL. HANDLE WITH APPROPRIATE CARE; CLEAN AND REPLACE OIL.

Flat Diaphragm Replacement

PulsaPro diaphragms do not have a specific cycle life; however, the accumulation of foreign material or the entrapment of sharp particles between the diaphragm and the dish cavity can eventually cause failures. Failure can also occur because of hydraulic system malfunction or chemical attack.

Flat Diaphragm Replacement Procedure:

- Disconnect the power source to the drive motor.
- Relieve all pressure from the piping system.
- Take all precautions to prevent environmental and personnel exposure to hazardous materials.
- Close the inlet and outlet shutoff valves.
- Place a suitable container underneath the pump head to catch any liquid leakage.
- Disconnect piping to the reagent head and drain process liquid, following material safety precautions described.
- Remove all but one top reagent head bolts. Oil will leak out between the pump head and reagent head as the bolts are loosened. The HPV will hold the reservoir of oil in the intermediate head but any oil between the diaphragm and dish plate will drain.
- Tilt the head and pour out any liquids retained by the check valves into a suitable container, continue to follow safety precautions.
- Remove the final bolt and rinse or clean the reagent head with appropriate material.
- Remove the old diaphragm and replace it with the new one supplied in the KOPkit.
- To install a diaphragm, first ensure that the critical sealing areas of the diaphragm, reagent head, and pump head are clean and free of debris. Set the diaphragm in place on the reagent head and ensure the seat of the diaphragm sealing ring into mating groove in the reagent head.
- Install the reagent head bolts and tighten in an alternating pattern to ensure an even seating force. Refer to torque values in torque table.
- Re-prime the pump head.

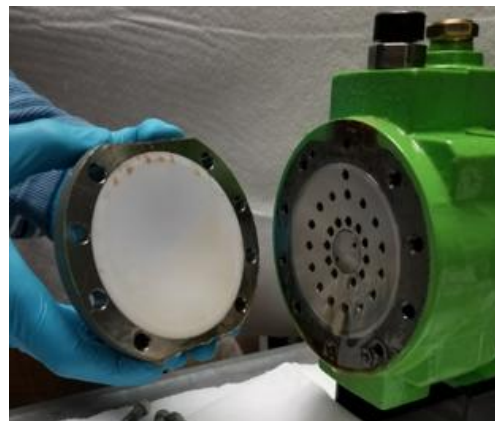

Figure 26

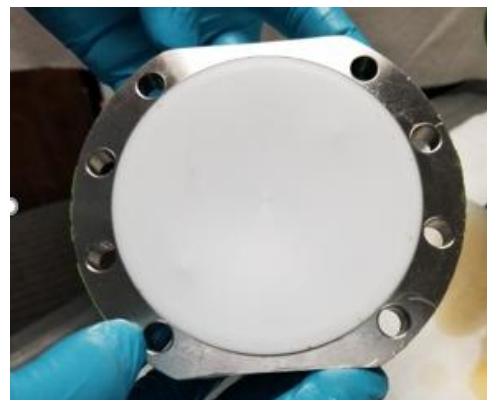

Figure 27

HYDRAtube Replacement

1. Remove all pressure from piping system.
2. Disconnect the power source to the drive motor.
3. Adequately flush the reagent head and associated piping with a neutralizing liquid to remove all toxic or hazardous product.
4. Close the suction and discharge shut off valves.
5. Disconnect the unions or flanges on the piping and drain off any liquid. Use extreme caution if the product is hazardous.
6. Remove the top fill plug from the HYDRAtube housing. Next place a pan under the housing and remove the bottom pipe plug to drain the intermediate fluid. Note – on models equipped with a CHEMALARM the bottom pipe plug is replaced with a conduction probe. Refer to separate instructions for removal and reinstallation of the probe.



Figure 28



IF THE DIAPHRAGM HAS FAILED, INTERMEDIATE LIQUID COULD HAVE PROCESS LIQUID MIXED INTO IT. IF THE PRIMARY DIAPHRAGM HAS ALSO FAILED, PRODUCT MAY HAVE CONTAMINATED THE PUMP OIL. HANDLE WITH PROPER CARE.

7. Remove the tie bars, valves, and valve adaptors from both suction and discharge.



FOR ELASTOMER HYDRATUBES FOLLOW STEPS 8 THROUGH 20. FOR PFA HYDRATUBES FOLLOW STEPS 21 THROUGH 35.

8. Pick up on the edge of the HYDRAtube flange and push that same edge down the throat of the HYDRAtube. The balance of the flange will fold and follow. (Figure 28)
9. Pull the HYDRAtube out from the bottom of the housing by a combination of twisting and bending sideways.
10. Inspect for any damage (i.e. cuts, cracks, chemical attack, or excessive deformation). Replace if necessary.



Figure 29

11. When installing a HYDRAtube do not use tools which may cut or damage the tube.
12. Obtain a rubber band
13. Fold a point on the edge of the flange upward. Push the edge down the throat of the tube. Fold the sides of the flange inward to form a compact 45° and wrap tightly with a rubber band. This wrapped nose should be reasonably compact and secure. (Figure 30)
14. Work with the wrapped nose of the tube up through the bottom hole of the housing, rotating gently to work the tube upward to the top of the housing.
15. With a slight push at the bottom flange of the tube, guide the nose of the tube to the center and out of the top hole in the housing.



Figure 30

16. If the HYDRAtube is one of the larger models, (inside is greater than 1 inch or 38.1mm) the time required to fill the housing can be reduced by pouring the intermediate liquid past the top flange while it is still folded.
17. Reinstall the bottom valve adaptor and drain plug and then partially fill the housing with the appropriate liquid.
18. Remove the rubber band.
19. Unfold the top flange and center both the top and bottom of the HYDRAtube (Figure 31)
20. Reassemble the top and bottom adaptor parts, torque the tie bar bolts to the recommended value.
21. If the HYDRAtube housing has been removed from the pump head and the hydraulic prime lost, follow the flat diaphragm re-priming procedure before re-priming the intermediate/housing chamber.



Figure 31

The following steps apply to PFA HYDRATUBES

22. Pick up the edge of the HYDRAtube flange and bend it upwards so that it is even with the body of the tube. Avoid creasing the tube material.
23. While keeping the flange bent up, lift and remove the HYDRAtube adaptor and any gaskets beneath it.

24. Pull the HYDRAtube out from the bottom by a combination of twisting and bending. Also remove any gaskets which were beneath the bottom tube adaptor.
25. Inspect the tube for any damage (i.e. cuts, cracks, chemical attack). Replace if necessary.
26. When installing a tube do not use tools which may cut or damage the tube
27. Obtain a rubber band.
28. Place one flat gaskets in the top recess of the HYDRAtube housing.
29. Check the bottom HYDRAtube adaptor, it should have one flat gasket on it. Carefully straighten the flange on one end of the tube and work it through the adaptor and gasket. Slide the adaptor and gasket to the opposite end of the HYDRAtube.



Figure 32a

30. Now tightly wrap the straightened end of the HYDRAtube with a rubber band. (Figure 32a)
31. Work the wrapped end of the HYDRAtube up through the bottom hole of the housing, rotating gently to work the HYDRAtube upward to the top of the housing.
32. With a slight push at the bottom flange of the tube, guide the nose of the HYDRAtube to the center and out the top hole in the housing.
33. Work the top tube adaptor over the top end of the tube. It may be necessary to remove the rubber band first.

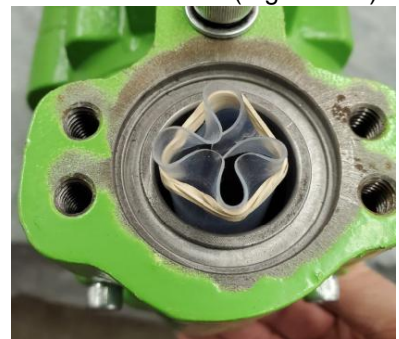

Figure 32b

34. Unfold the top flange and center both the top and bottom of the HYDRAtube. Make certain the HYDRAtube flanges are seated in the HYDRAtube adaptors.
35. Reassemble the top and bottom adaptor parts, torquing the tie bar bolts to the recommended value.
36. If the HYDRAtube housing has been removed from the pump and the hydraulic prime lost, follow the flat diaphragm re-priming procedure before re-priming the intermediate/housing chamber.

HYDRACONE Replacement

Like the HYDRAtube diaphragm, the HYDRACONE is not subject to stress fatigue and will not fail from repeated flexure. However, failure may occur as a result of improper prime, over-pressurization or chemical attack.

Follow these steps to replace the HYDRACONE diaphragm:

1. Close the inlet and outlet shut-off valves.
Adequately flush the reagent head, and associated piping with a suitable fluid to remove toxic or hazardous product. Vent off the reagent head pressure.
2. Disconnect the union or flange on the piping.
3. Place a pan under the pump head to catch oil leakage.
4. Remove the four reagent head bolts from the pump head.
5. Rotate the reagent head and pour the product pumped into a suitable receptacle.
6. Rinse the reagent head in water or a compatible liquid.
7. Remove the HYDRACONE from the reagent head. It may be necessary to use a sharp object to pry the HYDRACONE from the O-ring groove.
8. Insert the new HYDRACONE diaphragm and reassemble the reagent head in the reverse order of disassembly. Tighten all bolts securely and evenly.
9. On plastic reagent head designs, check the HYDRACONE adaptor O-ring to ensure it is intact.
10. Replacement of the HYDRACONE diaphragm will lose hydraulic prime in the pump.
11. Re-prime the hydraulics.
12. Pump is ready for service.

HYDRACONE Diaphragm

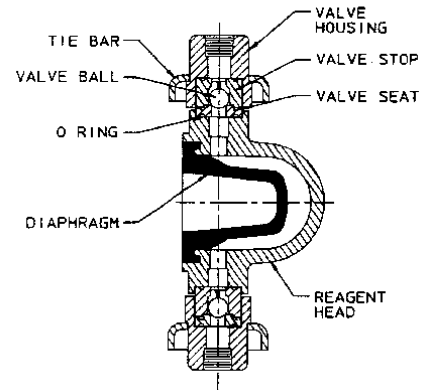

8.5 Priming

Flat Diaphragm Priming

1. Disconnect the power source to the drive motor.
2. Relieve all pressure from the piping system.
3. For the 680/880 models, remove the sight glass on the intermediate head and pour the appropriate amount of Pulsalube 6HGS. Replace the sight glass.
 - a. For PalsaPro V.2.0, utilize the diagnostic window.
4. For the 7120 model, remove the fill cap in the intermediate head and fill to the appropriate level with Pulsalube 6HGS. Replace the fill cap.
 - a. For PalsaPro V.2.0, utilize the diagnostic window
5. Remove the fill cap on the gearbox and fill the gearbox with Pulsalube 6HGS hydraulic oil to the proper level. Replace the fill cap after complete.
6. Turn on the pump and adjust the stroke length to the maximum setting of one hundred percent stroke. Fully depress and hold the PTP valve. Oil should begin to flow out of the center diagnostic port. Depress the PTP valve down for three to five seconds then release and repeat until the oil is clear of bubbles. The pump is now primed. If oil fails to flow out of the diagnostic port, re-check the oil levels.
7. If you continue to have issues, you can try to speed up the process. Set the stroke to Zero and isolate the power from the pump.
8. Remove the PTP valve from the pump head. Using a plastic funnel, slowly pour oil into the pump head through the PTP valve port until full.
9. Replace the PTP valve in the pump head, ensuring that the flat copper gasket and O-ring are properly in place.

10. Restore power to the pump. Increase the stroke slowly to 100% depressing and holding the PTP valve periodically. Oil should begin to flow out of the center diagnostic port. Continue to hold the valve down until the oil is clear of bubbles.
11. If oil fails to flow out of the diagnostics port, then additional oil is required: repeat steps 7-9.
12. The pump is fully primed and ready to put into service.

HYDRAtube

Before filling the HYDRAtube chamber you must first have performed the hydraulic priming of the flat diaphragm. If this has not been done, follow the instructions above for priming of a flat diaphragm. You must have the flat diaphragm and the HYDRAtube diaphragm in sync for proper operation. This process will place the flat diaphragm back with the tube diaphragm in a fully relaxed and open state.

The HYDRAtube, when properly primed, should be in its neutral position (fully round) when the diaphragm is in its rearmost position (as dictated by the piston, figure 33), and should begin to close as the diaphragm moves forward (figure 34). Priming in this way assures stable performance and protects the HYDRAtube from damage during system upsets. The priming procedure is the same for elastomer and PFA HYDRAtubes.

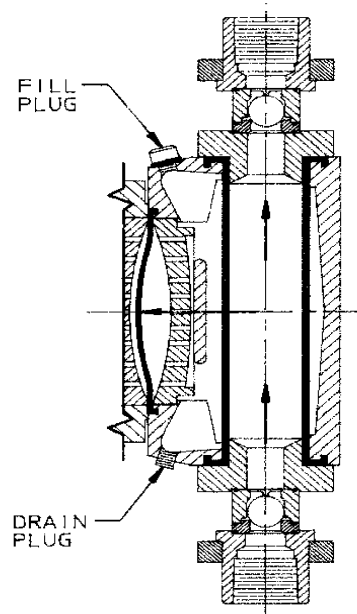

HYDRATUBE ON
SUCTION STROKE

Figure 33

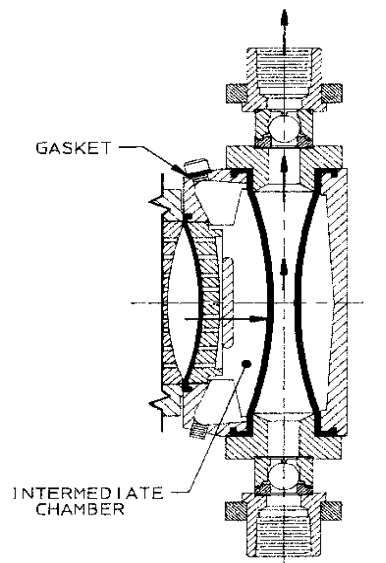

HYDRATUBE ON
DISCHARGE STROKE

Figure 34

- With the intermediate chamber fill plug removed, manually rotate the motor coupling until the pump piston assembly is in the full rearward position.
- Fill the intermediate chamber using a mixture of water and 1/3 propylene glycol by volume or other liquid selected for the application.
- Check the seal on the fill plug and replace if necessary. Reinstall and tighten the fill plug to the intermediate chamber.
- Reinstall the coupling guard and front reservoir cover. Allow the pump to run for 5 to 10 minutes. Observe the action of the HYDRAtube through the discharge port. It may be helpful to shine a light up through the suction port. It should go from a complete round form at the end of the suction stroke to an elliptical shape at full

discharge stroke, but not closing off at the middle. The pump now has a correct intermediate prime and is ready for service.

- Reinstall the suction and discharge valve assemblies.

HYDRAcone

1. Fill the pump with the appropriate oil.
2. Set stroke length adjustment to maximum stroke setting.
3. Turn on the pump motor.
4. Loosen the pressure relief valve located at the top of the hydraulic system to atmosphere and any air present will vent back into the gearbox oil reservoir as the automatic makeup valve fills the piston/diaphragm chamber. Air bubbles will be evident at the vent hole, top center of pump head behind return spring.
5. When last traces of air have been expelled retighten pressure relief valve.
6. Reconnect pump to process and adjust pressure relief valve to desired setting using pressure gauge in the process line. Approximately a ½ turn more after process pressure setting has been reached will seat valve. The valve can be set higher if desired but do not exceed Maximum Operating Pressure indicated on the pump nameplate.
7. After the pump has run for several hours, again check for any last traces of air at the pressure relief valve.

Double Diaphragm Flat Leak Detection

Please refer to Appendix I for detailed information for priming of the Leak Detection Diaphragm.

8.6 Check Valves

Description of Check Valves

Most fluid metering problems are related to check valves. Problems usually stem from solids accumulation between the valve and seat, corrosion of seating surfaces, erosion, or physical damage due to wear or the presence of foreign objects.

The check valve incorporates a ball or disc, guide, and seat. Flow in the unchecked direction lifts the ball or disc off the seat, allowing liquid to pass through the guide. Reverse flow forces the ball or disc down, sealing it against the sharp edge of the seat. The guide permits the ball to rotate but restricts vertical and lateral movement to minimize “slip” or reverse flow. Ball rotation prolongs life by disturbing wear over the entire surface of the ball.

Since check return is by gravity, the valve must be in the vertical position to function properly. The guide and seat are sealed by O-rings.

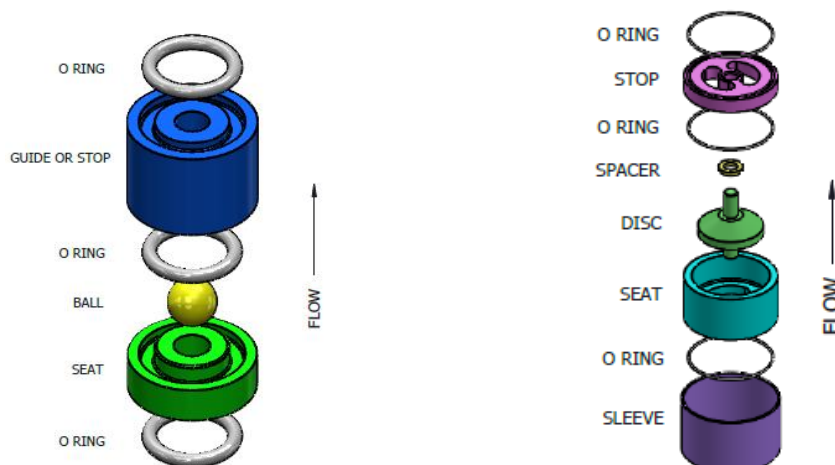

Figure 35

Removal, Inspection, and Reinstallation

With the removal of wet end components follow the recommended safety procedures in place and use your Personal Protective Equipment (PPE).

- Disconnect the power source to the drive motor.
- Relieve all pressure from the piping system.
- Take all precautions to prevent environmental and personnel exposure to hazardous materials.
- Close the inlet and outlet shutoff valves.
- Loosen the suction valve tie bar bolts and spring the suction piping slightly to drain any liquid from the reagent head cavity. If the piping is closely connected it may be necessary to disconnect a union or flange.
- Remove the suction check valve assembly (ball contained within guide and seat), holding it together as a unit.
- Loosen the tie bar bolts on the discharge valve and spring the piping slightly to drain any liquid.
- Remove the discharge valve assembly, holding it together as a unit as before.
- Disassemble both valves and examine components for wear. Seats should have sharp edges or a small chamfer, free from dents or nicks. Hold the ball firmly against its mating seat in front of a bright light to inspect for fit.



Figure 36



NOTE

OBSERVATION OF LIGHT BETWEEN THE BALL AND SEAT IS CAUSE FOR REPLACEMENT OF EITHER OR BOTH COMPONENTS. FOR BEST RESULTS, ALWAYS LOOSEN THE UNIONS OR FLANGES ON EITHER SIDE OF THE PIPING PRIOR TO RE-TIGHTENING OF THE CHECK VALVE ASSEMBLIES. RE-TIGHTEN THE UNIONS OR FLANGES AFTER THE CHECK VALVES ARE TIGHTENED INTO POSITION.



Figure 37

- Reassemble both valves using new parts as required. Sealing O-rings should always be replaced.
- Reinstall both valve assemblies, taking care to ensure that they are correctly orientated with balls above seats.
- Tighten the tie bar bolts evenly.
- Torque the tie bar bolts according to the torque specification list in Appendix IV

8.7 Hydraulic Performance Valve (HPV)

PulsaPro pumps utilize the high-performance valve which is integrated within the dish plate to preserve hydraulic balance. The valve is factory preset and requires no maintenance provided the hydraulic oil remains clean. When the valve is actuated, oil can flow into the hydraulic system until the piston reaches the end of the suction stroke.

As the piston starts forward a check valve prevents oil from flowing back through the HPV, thereby allowing the valve to close as the diaphragm moves forward. Through this process the diaphragm is continually maintained in a proper operating position relative to the pump head dish plate. Since the HPV is unaffected by the vacuum level in the pump head, oil cannot be inadvertently brought into the hydraulic system which would result in over extension and damage to the diaphragm. This feature provides the pump protection should the suction line become restricted or closed.

The check valve (HPVC) in series with the HPV includes a screen to trap contaminants and should be removed and cleaned with each change of hydraulic oil as indicated. A clogged filter screen will impede the operation of the HPV and can lead to diaphragm damage. If a diaphragm has failed, and chemical has contaminated the pump head assembly, both HPV and HPVC should be removed and thoroughly cleaned.

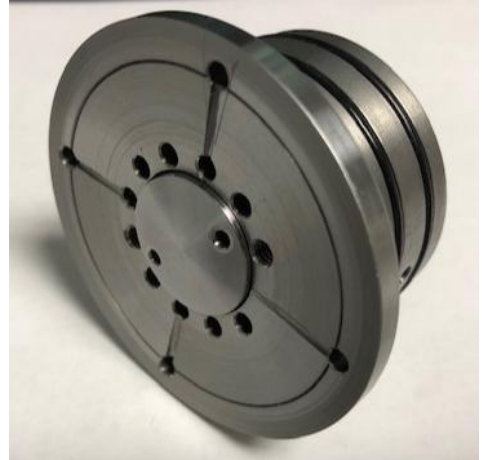

Figure 38

Check Valve Screen (HPVC) – Removal and Cleaning

- Disconnect power, relieve all pressure, and drain the hydraulic fluid.
- Unscrew the check valve from the bottom of the pump.
- Clean the valve and screen in a solvent compatible with the nitrile seal material and blow air through the valve to remove all contaminants.
- Inspect the copper gasket and O-ring for nicks or other damage and replace if necessary.
- Lubricate the O-ring with PULSAlube 6H and install the valve, tightening securely.
- Re-install the drain plug and refill the hydraulic oil.



Figure 39

8.8 Hydraulic Bypass Valve (HBV)

All PulsaPro pumps incorporate a hydraulic bypass valve which is an adjustable spring-loaded valve ported into the hydraulic cavity of the pump head. The valve is designed to protect the pump against excessive hydraulic pressure and will not limit or regulate system pressure. The valve is factory adjusted for pressure as originally specified, or at 10% above the rated pressure.

The HBV is located on the side of the pump head and any discharge, indicating over pressurization, is visible through the diagnostic port via sight glass. If adjustments are necessary in the field, remove the valve's plastic cover and loosen the lock nut. When turning the adjustment screw clockwise you will increase the bypass pressure, counterclockwise will decrease the bypass pressure. The locking nut must be tightened after adjustment.

For **PulsaPro Version 2.0**, the HBV is located at the 10 o'clock position of the pump head; i.e. - facing the wet end of the pump. Any discharge, indicating over pressurization is visible through the diagnostic window located on the top of the intermediate head.

Pump damage may occur during a system upset, if the hydraulic bypass pressure is set higher than 10% over the design pressure of the pump. Conversely, if the setting is too low the valve will operate on each discharge stroke. This results in decreased pumping capacity and will eventually affect the efficiency of the valve.

To check the hydraulic bypass pressure setting, install a pressure gauge and a regulating valve in the pump discharge line. The gauge must be between the pump and valve. For convenience, locate the two as close to the pump as possible. With the pump operating at maximum stroke length, gradually increase the discharge pressure and observe when the HBV starts to operate. The cracking pressure of the valve must be at least as high as the maximum pressure of the system but no more than 10% over the pumps rated pressure.

Periodic inspection of the valve is recommended. If it becomes worn or damaged leakage will occur.



Figure 40



Figure 41

8.9 Push to Purge (PTP)

The PTP is a gravity operated ball check valve that automatically removes gases from the hydraulic system. On each discharge stroke of the pump, hydraulic pressure drives the ball off the lower seat, expelling any accumulation of gases at the top of the hydraulic system. An upper seat limits ball travel and flow during each actuation. On each suction stroke, the ball is pre-positioned by gravity against the lower seat to prevent reentry of gas into the system. When all gas has been expelled, a small amount of oil will be displaced on each discharge stroke. This oil is returned by gravity to the hydraulic reservoir.

Under normal operating conditions this ongoing process removes accumulation of gas long before they are visible or detrimental to pump operation. To accelerate hydraulic startup, pressing the spring-loaded button at the top of the valve holds the valve momentarily open so that large amounts of gas can be instantly purged. When the button is released, the valve reverts to normal automatic operation. PTP operation can be monitored by observing oil flow from the diagnostic port through the sight glass. Any accumulation of solids can cause the valve to malfunction.



Figure 42

Removal, Cleaning, and Reinstallation of PTP

- Disconnect the pump from the power source.
- Relieve all pressure from the piping system.
- Slowly unscrew the valve to gradually relieve any residual hydraulic system pressure.
- Remove the valve and clean it by soaking in compatible solvent. Valve operation can be confirmed by blowing air through it in both directions and listening for the “click” sound of ball seat contact in both directions.
- Make sure that the copper gasket is installed at the bottom of the threaded hole in the pump head. It does not need replacement if it is undamaged.
- The elastomer gasket around the upper portion of the valve assembly may be likewise re-used.



THE VALVE IS NOT REPAIRABLE, AND MUST BE REPLACED IF IT CONTINUES TO MALFUNCTION AFTER CLEANING.

8.10 Piston Seals

PulsaPro piston seals are a thermoplastic elastomer with an FKM energizer seal. The seal is mounted two different ways: on the piston (for larger piston sizes) or in the cylinder (for smaller piston sizes). With oil changes at recommended intervals, piston assemblies should provide years of service.

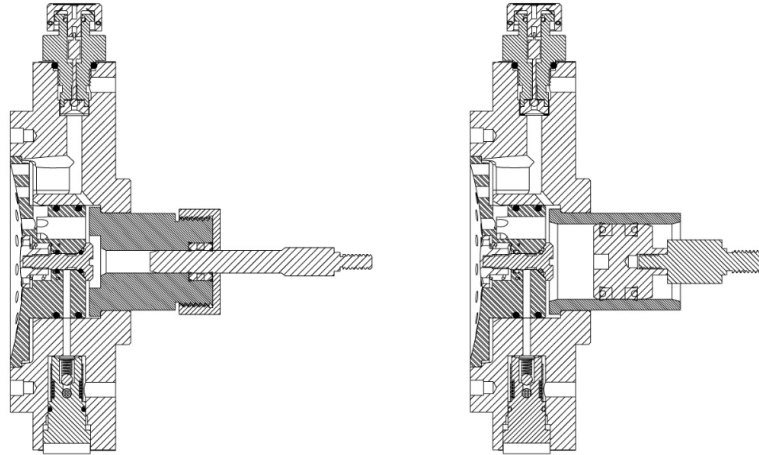

Figure 43
Removal and Replacement of Piston Seals (small piston sizes 7/8" and under)

- With any maintenance performed, follow safety procedures in place. Lockout/Tagout, relieve pressure, close valves, flush the reagent head, drain the hydraulic oil.
- Remove the reagent head from the pump head.
- Remove the four bolts that secure the pump head to the intermediate head.
- Loosen the nut at the end of the cylinder that holds the piston seals.
- With the nut removed from the cylinder, remove the piston seals. Install new piston seals into cylinder, follow same direction as removal.
- With the new seals installed, apply Loctite #242 (blue) to the threads of the nut and tighten. Torque nut to 50-foot pounds.



Figure 44



Figure 45

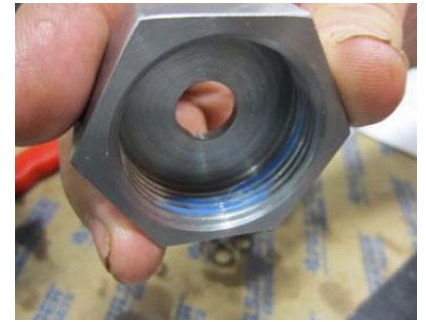

Figure 46

Removal and Replacement of Piston Seals (large piston sizes above 7/8")

- With any maintenance performed, follow safety procedures in place. Lockout/Tagout, relieve pressure, close valves, flush the reagent head, drain the hydraulic oil.
- Remove the reagent head from the pump head.
- Remove the dish plate from the pump head to have access to the piston.
- Using an Allen Wrench or ratchet, you can loosen the piston from the crosshead assembly (approximately 10 - 12 turns).
- Loosen and remove the four bolts that secure the pump head to the intermediate head. If the piston is unscrewed fully from the crosshead threads, it will come out with the pump head.
- Replacing the piston seals requires the purchase of a new piston assembly.
- Apply Loctite #242 (blue) to the back of the threads of the piston.
- Tighten piston assembly to crosshead.
- Reassemble the pump in reverse order.

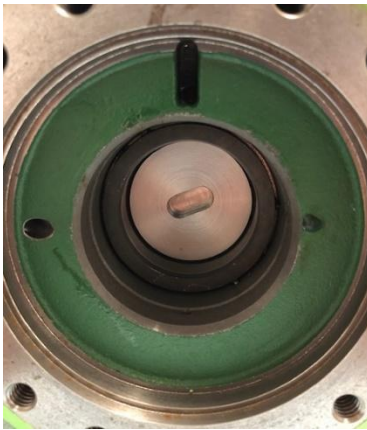

Figure 47

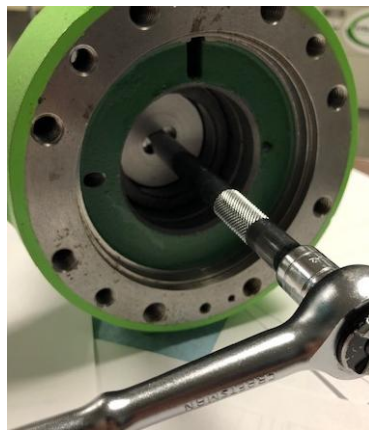

Figure 48

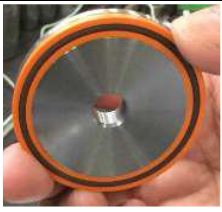



Figure 49

Removal and Replacement of Piston Seals (large piston sizes above 7/8") for pumps with multi-part piston assembly (implemented September 2021).

- Remove the reagent head from the pump head.
- Remove the bolt from the Hydraulic Bypass Valve and remove the HBV from the pump head. Removing the HBV will prevent damaging the O-rings.
- Remove three bolts and hex head from the intermediate head holding onto the pump head
- Use a rubber mallet to break the paint seal around intermediate/pump head.
- Remove pump head from the intermediate head. This will access the piston assembly.
 - Disassemble the assembly, removing the nut, piston plates and seals.



Remove the piston seal from the first piston plate and replacement with new seal.	Install the seal onto the second piston plate, with the energizer (black ring) facing up.	Install the second plate (with seal/energizer) onto the first plate.
		

Install the seal onto the third plate (energizer down)	Install the third plate (with seal/energizer) onto the rod. The seal should be facing down.	The plates/seals should be assembled, as shown below.
		

- Apply Loctite 242 onto the nut. Thread nut onto the piston cup assembly (above) and torque to 78 in.-lbs.
- In preparation for reassembly of pump head, apply pulsa-lube to lubricate the bore and piston seals.
- Lubricate O-rings on HBV and reinstall into pump head by tightening the nut.
- Ensure all of the O-rings are present on the intermediate head.
- Install the pump head into the intermediate head, reinstalling the three bolts and hex head.
- Reinstall the reagent head onto the reagent head. Torque reagent head bolts to values listed in Appendix IV.

8.11 Oil Seal

The PulsaPro pumps utilize an oil seal on the worm shaft (input shaft) like the Pulsa product line. This seal is serviceable, but only necessary to replace if there is an oil leak.

Replacing the Oil Seal

- Power has been disconnected from the source; safety procedures are followed.
- Remove the four fasteners securing the motor to the motor adaptor and remove motor.
- Rotate the coupling on the worm shaft until you see the set screw through the slots on the adaptor.
- Remove the four hex head cap screws securing the motor adaptor to the gearbox (Figure 50).
- With the motor adaptor removed, you have visibility of the tension nut and the oil seal, using a marker or equivalent put a mark on both tension nut and gearbox (Figure 51). This will provide a reference when reassembly is performed, ensuring that the nut is properly aligned.
- Remove the oil seal
- Place electrical tape or equivalent over the end of the worm shaft prior to installing new oil seal to prevent damage.
- Use Loctite # 534 around the outer surface of the oil seal (Figure 52).
- Press the oil seal onto the worm shaft and slide in place.
- Gently tap the oil seal flush into the tension nut.

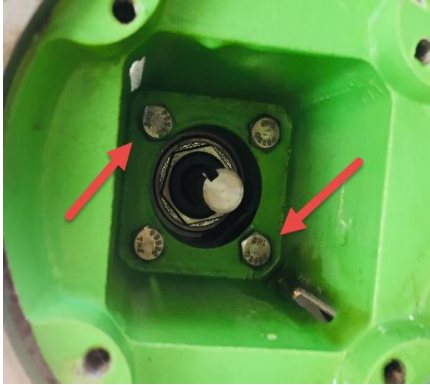

Figure 50



Figure 51



Figure 52

8.12 Pump Motor Removal & Reinstallation

- Disconnect the power source to the drive motor.
- Disconnect the motor wiring from the motor.
- Remove the four bolts retaining the motor to the motor adaptor and remove the motor.
- The coupling is an interlocking jaw design and uses an elastomer spider between two coupling halves. One half of the coupling remains on the worm shaft and the other on the motor shaft.
- Loosen the setscrew that retains the coupling half of the replacement motor, ensuring that the shaft key is in place.
- Align the end of the shaft flush with the inner surface of the coupling and tighten the setscrew.
- Reinstall the motor by reversing the steps.

9. Troubleshooting Chart

ISSUE	POSSIBLE CAUSES	REMEDY
Flow Rate Lower than Expected	Motor Speed too low	Check voltages, frequency, wiring, and terminal connections. Check nameplates vs. specifications.
	Check Valves worn or dirty	Clean, replace if damaged
	Hydraulic bypass valve operating each stroke	Refer to <i>Hydraulic Bypass Valve</i>
	Calibration system error	Evaluate and correct
	Product Viscosity too high	Lower viscosity. Increase pump and/or piping size
	Product cavitation	Increase suction pressure
	Piston seal worn or damaged by contamination	Inspect and replace if necessary, refer to Piston Seal (Section 8 Maintenance)
	Process pressure relief valve leaking or relieving	Repair, adjust or replace
Delivery gradually drops	Check Valve Leakage	Clean, replace if damaged
	Leak in Suction Line	Locate and correct
	Strainer Fouled	Clean or replace screen
	Product change	Check viscosity
	Bypass leakage	Correct for bypass valve leakage
	Piston seal worn or damaged by contamination	Inspect and replace if necessary, refer to Piston seal
	Supply tank vent plugged	Unplug vent
Pump does not start	Coupling Disconnected	Connect Coupling
	Faulty power source	Check power source
	Blown fuse, and circuit breaker	Replace – eliminate overload
	Broken Wire	Locate and repair
	Wired Improperly	Check wiring diagram and correct
	Pipeline blockage	Open valves
No Delivery	Motor not running	Check power source. Check wiring diagram
	Supply tank empty	Fill tank
	Lines clogged	Clean and flush
	Closed line valves	Open valves
	Ball check valves held open with solids	Clean and inspect
	Vapor lock, cavitation	Increase suction pressure
	Prime lost	Re-prime, and check for leak
	Strainer clogged	Remove and clean, replace screen if necessary
Delivery Erratic	Hydraulic system under-primed	Re-prime the pump
	Leak in suction line	Locate and correct
	Product cavitation	Increase suction pressure
	Entrapped air or gas in product	Ensure proper venting of system
	Motor speed erratic	Check voltage and frequency
	Fouled check valves	Clean, replace if necessary
Delivery higher than rated	Suction pressure higher than discharge pressure	Install backpressure valve or consult factory for piping recommendations
	Back pressure valve set too low	Increase setting
	Back pressure valve leaks	Repair, clean, or replace
	Calibration error	Review calculations
Pump loses hydraulic oil	Diaphragm ruptured	Replace diaphragm
	Leaky seal	Replace seal
	Cover gasket leaks	Replace or retighten

	Pump head gasket leaks	Replace – tighten pump head bolts. Apply sealing compound
	Pump head overfilled	Remove excess oil
Noisy gearing/knocking	Discharge pressure too high	Reduce pressure
	Water hammer	Install dampener
	Hydraulic bypass valve set too high	Readjust bypass valve
Piping Noisy	Pipe size too small	Increase size of piping
	Pipe runs too long	Install dampener in line
	Surge chambers flooded	Repair with air or inert gas. If dampener is installed, replace diaphragm and recharge
	No surge chambers used	Install dampener
Motor Overheats	Pump overloaded	Check operating conditions against pump design
	High or low voltage	Check power source
	Loose wire	Trace and correct

Diagnosis of Diaphragm Failure

FAILURE OBSERVED	POTENTIAL CAUSES
Puncture, surface wear, or physical damage	Abrasives or solids in the process stream Foreign object in process or hydraulic system
Extrusion and/or failure to the front (towards the process side)	Extended time under poor suction conditions, can include inadequate NPIP, closed valves, clogged strainers or filters, obstructed piping Malfunctioning High Performance Valve (HPV)
Extrusion and/or failure to the rear (towards the hydraulic side)	HPV filter screen clogged High (excessive) suction pressure Discharge pressure above maximum limit Leaking (damaged) discharge check valve
Change in surface characteristics, color	Chemical incompatibility with the process fluid

10. Technical Service Support

10.1 Authorized Service Centers

Pulsafeeder has several Authorized Service Centers across the United States to support the rebuilding and testing of your Pulsafeeder equipment along with onsite support. Contact your local sales representative for a service center near your location or Pulsafeeder directly.

10.2 Local Sales Representative

Your local Pulsafeeder Sales Representative has knowledge of Pulsafeeder Products and can provide technical service support. To be directed to the local sales office go to www.pulsafeeder.com and select "Sales Contacts" or contact Pulsafeeder directly to assist with locating the local Representative.

10.3 Factory Service Support

Pulsafeeder Field Service Engineers (FSE) are available for the following services around the globe:

- ✓ Maintenance and Operations Training Sessions, customized to the customer's requirements.
- ✓ Pre-startup inspections and startup testing/calibration of pumps and accessories.
- ✓ Field repair of pumps
- ✓ Assistance with system and installation issues.

The minimum charge for a service visit is four (4) hours labor, plus travel time and expenses.

For more details, please contact Aftermarket Service at proservice@idexcorp.com or contact us at 585-292-8000 to setup your onsite visit.

11. APPENDIX I

11.1 PULSAlarm® Leak Detection System

The PULSAlarm® leak detection system utilizes a two-layer PTFE diaphragm, coupled to a pressure switch. The system is initially primed by filling the void within the detection assembly and between the diaphragm layers with a barrier fluid. The setup process then bleeds excess fluid from between the diaphragm layers until they are in close contact.

During normal pump operation, the two layers of the PTFE diaphragm bear directly against one another, and there is no pressure generated between the two layers. The sensing system monitors the space between the layers, which will remain at zero pressure if the diaphragm layers remain undamaged.

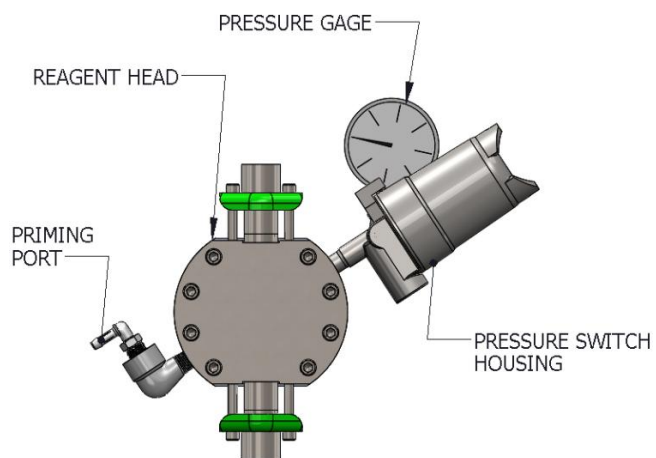

Figure 53

In the event of a failure of either layer of the diaphragm, liquid will enter the space between the two layers. This liquid will be either the hydraulic oil (if the rear layer fails) or the pumped fluid (if the front layer fails). As the pump operates, this liquid will generate pressure between the layers of the diaphragm that will then be transferred outwards by the barrier fluid. This fluid will create pressure against the pressure switch. The switch has a trip point of 20 PSI (1.37 BAR). When this pressure is reached the switch will operate.

The output of the switch (both normally closed, and normally open connections are available) can then signal the failure of the diaphragm. It is recommended that the pump be stopped in the event a leak is detected. Immediate attention to the problem, followed by cleanup and appropriate maintenance, will avoid further damage to the pump.

11.2 PULSAlarm® Leak Detection Diaphragm

Double, or sandwiched, PTFE diaphragms are sealed at the peripheries to an intermediate metal spacer ring. The space between the diaphragms is sealed so that the diaphragm functions as does a standard single diaphragm. The space is filled with a small amount of barrier fluid (silicon oil is factory default unless advised otherwise). This space is connected to an electrical switch that actuates in response to a buildup of pressure resulting from rupture of either or both diaphragms. Switch operation can be used to perform any external function, typically to signal an alarm or turn off the pump.

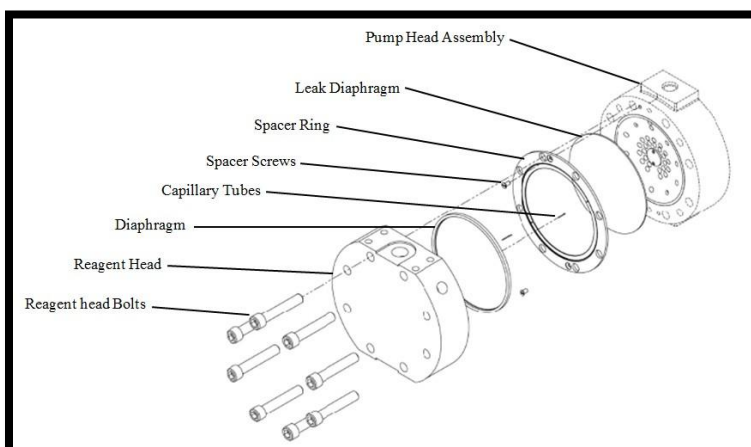

Figure 54

11.2.1 Reinstallation of Leak Detection Diaphragm

1. Ensure that the critical sealing areas of diaphragm assembly, reagent head, and pump head are clean and free from debris.
2. Ensure O-Ring is seated in the pump head as shown below.



3. Place a dab of grease on the back of the rear diaphragm. Note the rear diaphragm has swirls on the face. Apply grease to the side that does not have swirls and set in place on the pump head face as shown below.



4. Place the capillary tubes (2) into the holes located on the perimeter of the diaphragm.

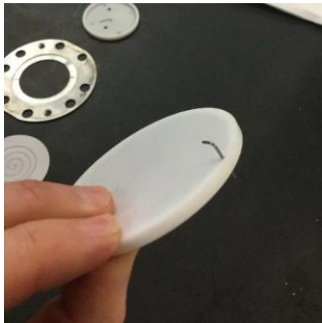

5. Once inserted, the capillary tubes should be orientated as shown below.



6. If possible, use compressed air to ensure the tubes are free of debris.
7. Push the capillary tubes down so that they are flush with the surface of the diaphragm as shown below.



8. Turn the diaphragm over and place the O-Rings onto the capillary tubes. Push them down until they meet the lip of the diaphragm.



9. Place the diaphragm onto the reagent head; ensuring the capillary tubes are seated into the pre-drilled holes in the reagent head.

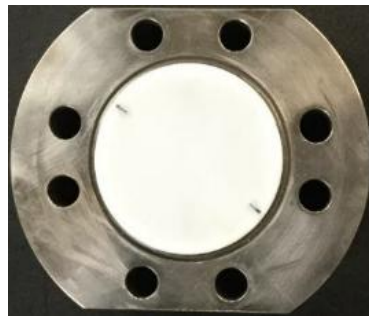

10. Place the Teflon O-Ring around the perimeter of the diaphragm. The O-Ring will need to be stretched slightly to fit tightly to the diaphragm. Note – 1.5" thru 1.94" dish sizes require this O-Ring; 2.25" thru 6" dish sizes there is no O-Ring.



11. Place the leak detection spacer onto the diaphragm. Ensure that the capillary tubes are in the slots as shown.



12. Place two (2) clips onto the assembly to hold the spacer and diaphragm in place.



13. Place the two reagent head bolts into the reagent head.

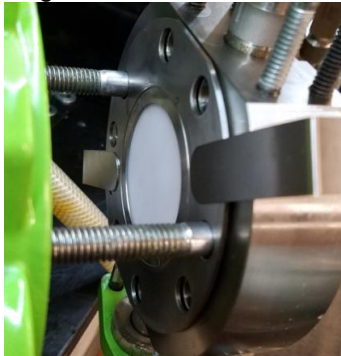

14. Slide the reagent head forward onto the pump head and hand tighten the bolts until the head of the bolt touches the reagent head.

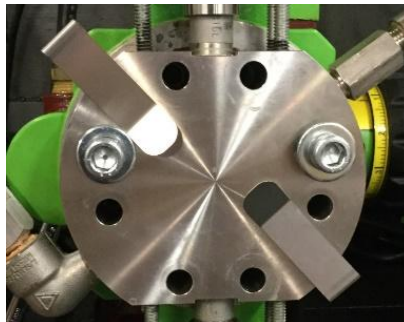

15. Once attached, remove the clips as shown

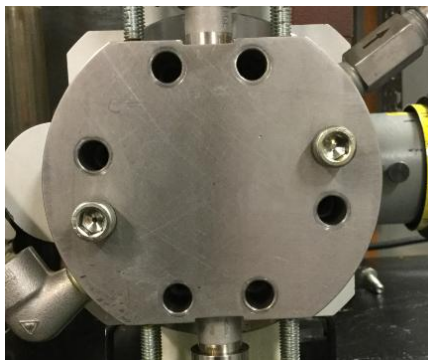

16. Install remaining head bolts. Torque the bolts per the recommended torque settings.

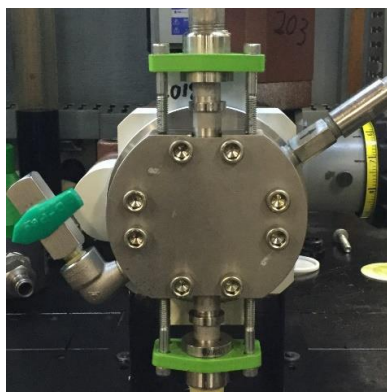

11.3 Priming of Leak Detection Diaphragm



NOTE

IF THE LEAK DETECTION SYSTEM IS OPENED TO THE ATMOSPHERE DURING MAINTENANCE OR INSPECTION, THE SYSTEM MUST BE RE-PRIMED PROPERLY TO AVOID DIAPHRAGM DAMAGE AND ENSURE PROPER LEAK DETECTION OPERATION AND SYSTEM PERFORMANCE.



THE STANDARD FACTORY INTERMEDIATE FLUID IS A SILICON OIL. IF ANY OTHER CUSTOMER SPECIFIED MEDIA IS USED, IT MUST BE COMPATIBLE WITH THE MATERIALS OF CONSTRUCTION.

1. Complete re-assembly of the diaphragm, reagent head, and external components. Ensure that the reagent head and tie bar bolts are tightened according to the appropriate torque specifications (Appendix IV).
2. Remove the pressure gauge from the housing body and replace with the straight tubing connection that is supplied with the pump.
3. Install a short length of the appropriately sized tubing to the fitting and connect a vacuum supply (either handheld or electric vacuum pump).
4. Remove the pipe plug from the fill port and install the 90° fitting supplied with the pump.

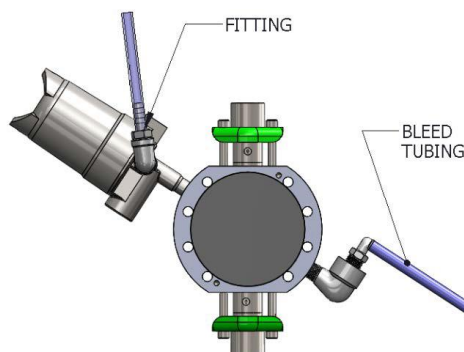

5. Install a short length of the appropriately sized tubing to the fitting and place tube into the container of the barrier fluid being used.
6. Apply a vacuum, the fluid should rise into the fill tube and enter through the system.
7. Observe the fluid at the exit (vacuum pump) side. When clear, air free fluid is observed, close the fill valve, while maintaining the vacuum on the system for approximately 2 -3 minutes to begin the process of drawing out excess fluid.
8. Remove the vacuum source and leave the tube on the outlet side (pressure gauge) open to atmosphere.
9. If the pump is not already hydraulically primed, remove the PTP valve from the top of the pump head. Using a plastic funnel or similar, slowly pour hydraulic fluid into the pump head cavity until full.
10. Inspect the PTP valve to ensure the sealing O-ring is still in position and re-install the valve.
11. Adjust the pump to full (100%) stroke.
12. To fully balance and evacuate the leak detection system, the pump must now run at normal discharge pressure for a period of about thirty minutes to one hour.
13. Supply either process fluid, or test fluid (i.e. water) to the suction fitting and ensure that the discharge system is configured for safe operation. The pump can be started with minimal discharge pressure and then slowly brought up to full pressure, if the system allows for this.
14. Apply power and start the pump. Hold down the PTP valve momentarily and observe the port via sight glass. Continue to depress the PTP to release any entrapped air within the hydraulics until you observe oil from the sight glass.
15. Slowly increase the discharge pressure to full operating pressure and continue to run the pump for a period of one hour.
16. During this time, excess barrier fluid will be displaced from the system into the short length of the tubing attached to the exit port, balancing the system for proper operation. A small pen mark on the tube can assist in observing this process visually.
17. After the one-hour startup period, remove the tubing and connection from the housing body and reinstall the pressure gauge.
18. Reconnect the alarm to the external system if necessary.
19. The pump and pressure leak detection system are now properly prepared and ready for normal service. During normal operation, the gauge should indicate zero (0) pressure.

12. APPENDIX II

12.1 Piping Calculations

All reciprocating metering pumps require a net positive suction head (NPIPR). Refer to Table 1 for the (NPIPR) required for PULSAPRO pump models. The NPIPR is defined as the pressure required above the absolute vapor pressure of the process fluid at the pumping temperature. This pressure is required at the suction port of the pump throughout the entire pump stroking cycle to prevent cavitation of the process fluid within the reagent head. The NPIPR is one of the requirements necessary to assure metering accuracy.

NPIPR	PULSAPRO
English (psi)	5
Metric (bar)	0.34

Table 1

The net positive suction head available (NPIPA) must be greater than the NPIPR. The NPIPA of any given system is calculated as follows for comparison to the NPIPR as shown in Table 1.

Equation # 1 – For fluid viscosity below 50 centipoises

$$NPIP_A = P_A \pm P_H - P_V - \left(\frac{L_S R G Q}{C_1 d^2} \right)$$

Equation # 2 – For fluid viscosity above 50 centipoises

$$NPIP_A = P_A \pm P_H - P_V - \sqrt{\left(\frac{L_S R G Q}{C_1 d^2} \right)^2 + \left(\frac{L_S \mu Q}{C_2 d^4} \right)^2}$$

Refer to Section 12.3 Nomenclature, for the definitions of variables used in the equations above; follow the units shown in Table 3B for the constants listed to be used correctly.



IF PIPING SIZES VARY THROUGHOUT THE SUCTION LINE, DIFFERENT ADDITIVE VALUES MAY BE USED FOR PRESSURE LOSSES ATTRIBUTED TO THE LIQUID'S ACCELERATION AND DECELERATION. USE THE LAST TERM OF EQUATION 1 OR 2 AS MANY TIMES AS NEEDED IN THE EQUATION TO ADJUST FOR DIFFERENT LENGTHS OF DIFFERENT PIPE DIAMETERS IN THE SUCTION LINE. (EVERYTHING BUT THE PIPE LENGTH AND DIAMETER WILL STAY THE SAME IN THE EQUATION).

All reciprocating metering pumps also require that a minimum absolute pressure and minimum suction head (msh), be maintained at the pump inlet throughout the pumping cycle to ensure a stable hydraulic system and proper pump operation. The sum of the NPSHa and the vapor pressure (pv) must be greater than the values shown in table 2.

MSP	PULSAPRO
English, (psia)	7.5
Metric, (bar(a))	0.53

Table 2 - Minimum values for the sum of NPIPA and vapor pressure. (MSP)

12.2 System Back Pressure

The system back pressure must exceed the suction pressure by at least five (5) psi (0.35bar) to prevent flow through, however it must not exceed the rated discharge pressure of the pump. Flow through can be defined as the process liquid flowing from a higher pressure to a lower pressure, which attributes to pump failure and undesired flow at pump shutdown. If the system back pressure is not at least five (5) psi (0.35bar) greater than the suction pressure, a back-pressure valve must be installed in the discharge piping. To calculate the system's total backpressure, use Equation 3 or 4.

Equation # 3 – For fluid viscosity below 50 centipoises

$$P_T = \left(\frac{L_s R G Q}{C_1 d^2} \right) + P_P \pm P_H$$

Equation # 4 – For fluid viscosity above 50 centipoises

$$P_T = \sqrt{\left(\frac{L_s R G Q}{C_1 d^2} \right)^2 + \left(\frac{L_s \mu Q}{C_2 d^4} \right)^2} + P_P \pm P_H$$

12.3 Nomenclature

Table 3A – Definitions of abbreviations used in NPIP Equations

NPIPR	Net positive inlet pressure required, [psi, bar]
NPIPA	Net positive inlet pressure available, [psi, bar]
PA	Pressure at the surface of the liquid being pumped (atmospheric or supply tank blanket pressure) [psi(a), bar(a)]
PH	Head pressure above (+) or below (-) the pump centerline, [psi, bar,] (convert from ft or m)
PV	Absolute vapor pressure at pumping temperature of the process liquid at pump inlet, [psi(a), bar(a)]
LS	Length of suction piping (actual, not equivalent), [ft, m]
R	Pump stroking rate, strokes/min [spm]
G	Specific gravity of process liquid, [no units]
Q	Pump average flow rate, [gph, lph]
d	Internal pipe diameter, [inches, mm]
C1, C2, C3	Numeric constants used in Equations 1 - 4 [no units] see table 2 for values
μ	Viscosity of process liquid at pumping temperature, centipoise [cp]
LD	Length of discharge piping (actual, not equivalent), [ft, m]
PP	System discharge pressure, [psi(g), bar(g)]
PT	Peak pump discharge pressure at the discharge port, [psi(g), bar(g)]
VP	Peak liquid velocity generated by the pump, (suction or discharge) [ft/s, m/s]

Table 3B – Unit sets and constant values for use in NPIP Equations

Variable	Units Set	
	English	Metric
NPIP	psi	bar
PA	psia	bar(a)
PH	psi	bar
PV	psia	bar(a)
LS	feet	meters
R	strokes/min	strokes/min
G	no units	no units
Q	gallons/hr.	liters/hr.
d	inches	millimeters
μ	centipoise	centipoise
LD	feet	Meters
PT	psi	bar
PP	psi	bar
VP	feet/sec	meters/sec
C1	24,600	640
C2	45,700	1.84
C3	46.8	0.91

13. APPENDIX III

13.1 Oil Specification

PULSAIube Ultra 6HGS Synthetic Hydraulic & Gear Oil

IMPORTANT HEALTH, SAFETY, AND ENVIRONMENTAL INFORMATION

Relative Density (at 15 °C):	0.86
Flammability (Solid, Gas):	N/A
Flash Point [Method]:	>210°C (410°F) [ASTM D-92]
Flammable Limits (Approx. volume % in air):	LEL: 0.9 UEL: 7.0 Autoignition
Temperature	N/D
Boiling Point / Range:	> 316°C (600°F)
Decomposition Temperature:	N/D
Vapor Density (Air = 1):	> 2 at 101 kPa
Vapor Pressure	< 0.013 kPa (0.1 mm Hg) at 20 °C
Evaporation Rate (n-butyl acetate = 1):	N/D



Please visit our website at www.pulsafeeder.com to view and download any Safety Data Sheet (SDS) under the Support tab.

14. APPENDIX IV

14.1 Bolt Torque Recommendations

For Models with Metal Heads and PTFE Diaphragm:

REAGENT HEAD BOLTS				TIE BAR BOLTS		
Reagent head Bolts	# Bolts and Thread size	Torque (2)		# Bolts and Thread size	Torque (2)	
		FT-LBS	N-M		IN-LBS	N-M
MW160007	(8) 3/8-16	23	31	(4) 1/4-20	18	2
MW160008	(8) 3/8-16	23	31	(4) 1/4-20	18	2
MW160057	(8) 3/8-16	23	31	(4) 1/4-20	18	2
MW160054	(8) 3/8-16	23	31	(4) 1/4-20	18	2
MW160013	(8) 3/8-16	29	39	(4) 1/4-20	18	2
MW160009	(8) 3/8-16	29	39	(4) 1/4-20	18	2
MW160014	(8) 5/16-18	17	23	(4) 1/4-20	42	5
MW160010	(8) 5/16-18	17	23	(4) 1/4-20	42	5
MW160015	(8) 7/16-14	34	46	(4) 5/16-18	47	5.5
MW160011	(8) 7/16-14	34	46	(4) 5/16-18	47	5.5
MW160069	(8) 7/16-14	34	46	(4) 5/16-18	13	1.5
MW160073	(8) 7/16-14	34	46	(4) 5/16-18	13	1.5
MW160004	(6) 1/2-13	35	48	(4) 1/2-13	13	1.4
MW160012	(6) 1/2-13	35	48	(4) 1/2-13	13	1.4
MW160053	(6) 1/2-13	35	48	(4) 1/2-13	30	2.4
MW160075	(6) 1/2-13	35	48	(4) 1/2-13	30	3.4

For Models with Metal Heads and Metal Diaphragms:

REAGENT HEAD BOLTS				TIE BAR BOLTS		
Reagent head Bolts	# Bolts and Thread size	Torque (2)		# Bolts and Thread size	Torque (2)	
		FT-LBS	N-M		IN-LBS	N-M
MW160076	(4) 3/8-16	3	4	(4) 1/4-20	12.0	1.3
MW160022	(4) 3/8-16	3	4	(4) 1/4-20	12.0	1.3
MW160074	(4) 3/8-16	3	4	(4) 1/4-20	12.0	1.3
MW160055	(4) 3/8-16	3	4	(4) 1/4-20	12.0	1.3
MW160018	(4) 3/8-16	3	4	(4) 1/4-20	12.0	1.3
MW160023	(4) 3/8-16	3	4	(4) 1/4-20	12.0	1.3
MW160019	(8) 5/16-18	2	3	(4) 1/4-20	12.0	1.3
MW160024	(8) 5/16-18	2	3	(4) 1/4-20	12.0	1.3
MW160020	(8) 7/16-14	9.0	12	(4) 5/16-18	15	1.7
MW160025	(8) 7/16-14	10	14	(4) 5/16-18	15	1.7
MW160021	(6) 1/2-13	15.0	20	(4) 1/2-13	30	3.4
MW160026	(6) 1/2-13	15.0	20	(4) 1/2-13	30	3.4
MW160056	(6) 1/2-13	15.0	20	(4) 3/8-16	18	2
MW160058	(6) 1/2-13	15.0	20	(4) 3/8-16	18	2
MW160064	(4) 3/8-16	3	4	(4) 1/4-20	12.0	1.3
MW160065	(8) 5/16-18	2	3	(4) 1/4-20	12.0	1.3
MW160067	(8) 7/16-14	9.0	12	(4) 5/16-18	15	1.7
MW160070	(4) 3/8-16	3	4	(4) 1/4-20	12.0	1.3
MW160071	(8) 5/16-18	2	3	(4) 1/4-20	12.0	1.3
MW160072	(8) 7/16-14	9.0	12	(4) 5/16-18	15	1.7

For Models with PTFE/PVC Heads and PTFE Diaphragm:

REAGENT HEAD BOLTS				TIE BAR BOLTS		
Reagent Head#	# Bolts and Thread Size	Torque (2)		# Bolts and Thread Size	Torque (2)	
		FT-LBS	N-M		IN-LBS	N-M
W204374	(8) 5/16-18	1.5	2.0	(2) 1/4-20	3.0	0.3
W203668	(4) 3/8-16	5.9	8.0	(2) 3/8-16	9.3	1.1
W204785	(6) 1/2-13	10.2	13.8	(2) 1/2-13	21.0	2.4
W209925	(6) 1/2-13	8.8	11.9	(2) 3/8-16	17.8	2.0
W204008	(6) 3/4-10	29.9	40.5	(2) 5/8-11	68.0	7.7
W204829	(6) 3/4-10	47.7	64.7	(2) 1/2-13	90.6	10.2

For Models with Hydratube Head and Metal Valves:

REAGENT HEAD BOLTS				TIE BAR BOLTS		
Reagent Head#	# Bolts and Thread Size	Torque (2)		# Bolts and Thread Size	Torque (2)	
		FT-LBS	N-M		IN-LBS	N-M
W094147	(8) 5/16-18	5.8	7.9	(2) 5/16-18	15.2	1.7
W094544	(4) 3/8-16	9.8	13.3	(2) 3/8-16	15.5	1.8
W094689	(4) 1/2-13	22.9	31.0	(2) 1/2-13	52.1	5.9
W096319	(4) 3/4-10	67.3	91.2	(2) 1/2-13	90.2	10.2

For Models with Hydratube Head and PTFE Valves:

REAGENT HEAD BOLTS				TIE BAR BOLTS		
Reagent Head#	# Bolts and Thread Size	Torque (2)		# Bolts and Thread Size	Torque (2)	
		FT-LBS	N-M		IN-LBS	N-M
W094147	(8) 5/16-18	1.5	2.0	(2) 5/16-18	3.8	0.4
W094544	(4) 3/8-16	5.9	8.0	(2) 3/8-16	9.3	1.1
W094689	(4) 1/2-13	15.2	20.6	(2) 1/2-13	47.5	5.4
W094689	(4) 1/2-13	15.2	20.6	(4) 3/8-16	17.8	2.0
W096319	(4) 3/4-10	44.9	60.9	(2) 1/2-13	4.8	6.2



The torque value is based on the reagent head part number which is stamped or cast on the part itself. If assistance is needed in identifying your specific torque value for your pump please contact the local representative or the Pulsafeeder Service Group at 585-292-8000 or via email at ProService@idexcorp.com

15. APPENDIX V – Accessories

15.1 PULSAtrol Pulsation Dampener

The PULSAtrol is a pneumatically charged diaphragm-type chamber that intermittently stores energy. Used on the inlet, it will improve NPIPA (Net Positive Inlet Pressure available) characteristics of the suction piping system. On the discharge line it will reduce peak pressures and pulsating flow variations.

Installation

On both discharge and suction lines, it is desirable to mount the PULSAtrol as close to the pump connection as possible. It can be mounted in any position: horizontally, vertically, or at any angle. A shutoff valve should always be used between the piping system and PULSAtrol. If the discharge line is open to atmospheric pressure, a backpressure valve should also be incorporated in the system near the PULSAtrol to assure proper operation. Pulsation dampeners do require regular maintenance and inspection. Charge pressure should be checked every 2 – 4 months and renewed as needed. Temperature, pressure, and other variables will affect charge life and diaphragm/bladder life.

Discharge Setup

The PULSAtrol may be pre-charged with air or nitrogen. When properly pre-charged the diaphragm is positioned against the bottom liquid chamber. It is therefore necessary to drain all liquid below the diaphragm and vent to atmospheric pressure when pre-charging.

Use the pre-charge pressure as determined from the PULSAtrol selection and sizing procedure. This can vary from 50 to 80% of mean line pressure in accordance with fluctuation level selected. The PULSAtrol is now ready for service and the diaphragm will move to a neutral position as liquid enters the chamber.

Pre-Charge Procedure for Discharge Installation

1. Calculate the pre-charge pressure
 - a. Mean line pressure (psig) + Atmospheric Pressure = Absolute Pressure (psia)
 - b. Absolute Pressure (psia) x Pre-charge percentage (80% max) = Pressure Absolute
 - c. Pressure Absolute – Atmospheric Pressure = Pre-charge Pressure (psig)
2. Isolate PULSAtrol from line
3. Carefully drain off process fluid by open a drain valve
4. Apply pre-charge pressure (additional liquid may drain as diaphragm moves)
5. Close drain valve
6. Place PULSAtrol in stream

Suction Setup (Flooded Suction)

Charge the PULSAtrol with adequate pressure to overcome the static suction head. Start up the pump. Depress the stem on the charge valve, but only during discharge strokes of the pump, until the gauge indicates pressure pulses. The diaphragm has now centered allowing the PULSAtrol to accumulate liquid while the pump is discharging. If too much air becomes released and the gauge will not indicate pressure pulses, recharge the PULSAtrol and repeat the procedure.

Pre-Charge Procedure for Suction Installation

1. Isolate accumulator from line
2. Carefully drain off process fluid by opening a drain valve
3. Apply 5 – 10 psi pre-charge pressure (additional liquid may drain as diaphragm moves)
4. Close drain valve
5. Bleed off all pressure on the PULSAtrol
6. Open the valve to put PULSAtrol in stream

7. Push in on the stem of the charging valve during the discharge stroke of the pump and release during the suction stroke
8. Continue this for about ten times and observe the compound gauge. As accumulator functions, the needle will go from pressure to vacuum

15.2 Back Pressure Valve

The Pulsafeeder diaphragm backpressure valve creates constant backpressure. A PTFE diaphragm, offering maximum chemical protection and service life, seals the spring and bonnet from process fluid. This diaphragm seals directly on a replaceable seat. Be sure to install with fluid flow in direction of arrow on valve body. If arrow is missing from plastic valve body, install with flow exiting out center hole of valve body.

15.3 Pressure Relief Valve

Pressure relief valves should be utilized in any system to protect the pump and other process equipment and piping from potentially damaging or unsafe pressures. It is critical that the pressure relief valve be mounted in the discharge piping system before any other devices that can potentially block or impede flow, or it cannot perform its intended function. The pressure relief valve must be set to a pressure high enough to prevent unwanted fluid relief during normal process conditions. A setting that is approximately 10-20% above normal operating pressures is generally enough. The valve must also be set below the maximum pressure capability of the lowest rated device in the system. For example, if a PulsaPro pump is rated with a maximum pressure capability of 150 psi (approx. 10bar) but the piping within the system is rated only to a maximum of 100 psi (approx. 7 bar) then the pressure relief valve must be set to a value lower than 100 psi.



Pulsafeeder, Inc.
2883 Brighton Henrietta Town Line Road
Rochester NY 14623
+1 (585) 292-8000
www.pulsafeeder.com