

BLACKLINE PRO

The Blackline Pro is based on Pulsafeeder's proven mechanical diaphragm pump technology with the addition of a variable speed drive controller. The unit comes with ten different operating modes, fully configurable, allowing you to fit the pump in any advanced pumping process where the unit needs to be controlled remotely and automatically.

The Blackline Pro comes in a variety of flows and pressures as well as wet-end materials allowing you to find the best pumping solution for any application.

A full aluminum gearbox and control unit housing with corrosion resistant EPD coating resulting in one of the most rugged and purposeful metering pumps on the market.

Form follows function: the angled back-lit display and single jog dial element, make this an extremely versatile and simple to use metering pump. The Blackline Pro is also available backward compatible meaning you can order as a kit and retro fit to an existing Blackline pump in the field.



FEATURES

- 10 operating modes to fit any application - Constant, Batch, Pause-Work, Proximity, Analog mA, Analog Volt, PPM, Pause-Percent, MLQ, Pulse
- Intuitive color coded display messages - Running, Warning and Alarm
- Variable gearbox orientation from 0 - 90°
- Backwards compatible possible installation on existing Blackline pump
- Aluminum casing with IP65/NEMA4X enclosure protection
- Ergonomical display clear and easy to read
- User friendly JDS - Jog-dial selector

APPLICATIONS

- Water & Wastewater
- Pulp & Paper
- Automotive
- Chemical Process
- Metal Process
- Power Generation

SELECTION

MODEL		MD1A	MD1B	MD1C	MD1D	MD1E	MD2F	MD2J	MD2K	MD3G
Capacity nominal (max.)	GPH	7	14	22	29	35	59	79	98	132
	LPH	26	53	83	110	132	223	299	371	500
Pressure (max.)	PSIG	150	150	150	150	150	90	90	75	75
	BAR	10	10	10	10	10	6	6	5	5
Strokes/Minute	SPM	84	60	84	116	138	84	118	138	118
Viscosity	CPS	1000			500		1000	500		
Connections:	FNPT	1/2"				3/4"				1"
	BSPT-F	1/2"				3/4"				1"

ENGINEERING DATA

Max. Flow Rate	132 gph / 501 lph
Max Pressure	150 psi / 10 bar
Max. Stroke Frequency	138 strokes/min
Liquid Temperature	14°F to 104°F / -10°C to 40°C
Max. Weight	62 lbs / 28 kg
Precision	±1%
Linearity	±5%
Accuracy of Repeatability	±3%
Max. Suction Lift	2 m
Turndown Ratio	500:1
Sound Pressure @ 3.3 ft / 1 m	<65 dbA
Materials (Actuator, Casing, Motor)	Aluminum
Finishing (Actuator, Casing)	Electrophoretic deposition (EPD)
Max Power Consumption	750W
Power Supply	110-240 VAC - Universal
Frequency	50/60 Hz
Operating Temperature	14°F to 113°F / -10°C to 40°C
Max Inrush Current	2.3A (110V) - 5A (230V)
Enclosure Class (Actuator Only)	IP65 / NEMA 4X
Recommended Fuse	6.3 x 32mm 8A
USB Type	USB 2.0 HOST
Serial Communications	MODBUS - RS-485

Input	4-20 mA	Input Voltage / Control Input	14 VDC
		Impedance	120 Ω
	Pulse	Max Load	28 VDC
		Max Resistance in Pulse Circuit	15 KΩ
		Min Pulse Length	10 ms
	Remote	Max Load START/STOP Digital Input	28 VDC
Max Load STOP Digital Input		28 VDC	
Output	Level	Max Load START Digital Input	28 VDC
	4-20 mA	Input Voltage /Control Input	14 VDC
		Relays	Max Load

PUMP HEAD MATERIALS

Pump Head	PP	PVDF	PVDF	316SS
Diaphragm	PTFE	PTFE	PTFE	PTFE
Valve Guide	PP	PP	PVDF	PP
Valve Seat	PVC	INCOLOY-825	PTFE	316SS
Valve Ball	PYREX	HASTELLOY C-276	PYREX	316SS
Valve Housing	PP	PP	PVDF	316SS
Valve Seal	FPM	FPM	PTFE	FPM
NPT Connectors	PVC	PVDF	PVDF	316SS

DIMENSIONS

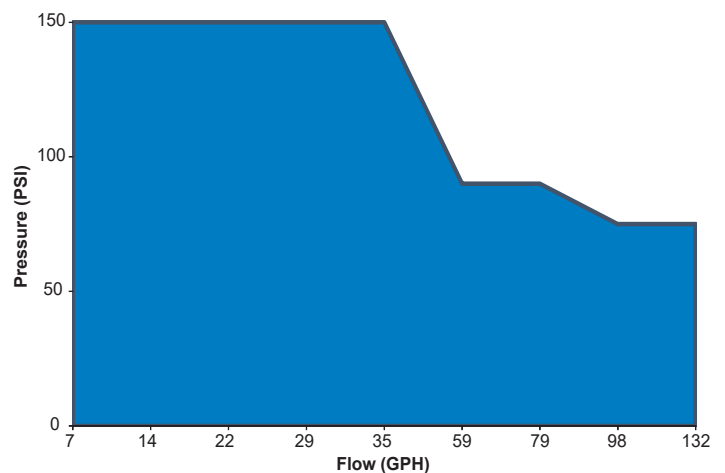
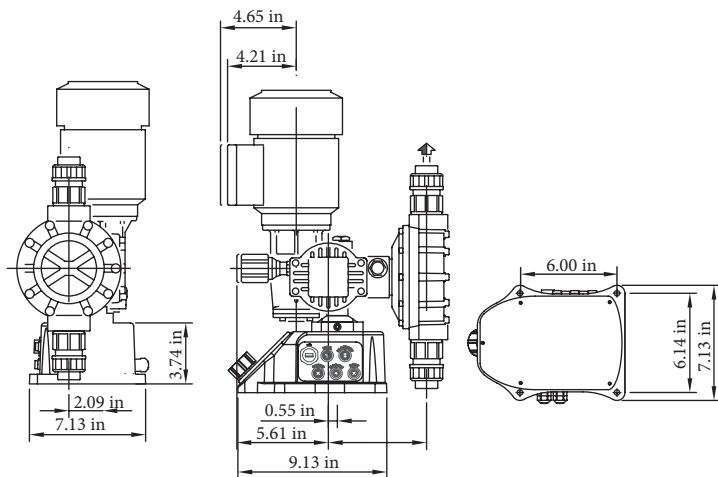

27101 Airport Road
Punta Gorda, FL 33982
Tel: (941) 575-3800
www.pulsafeeder.com



An ISO Certified Company

IBEX
BLP001 E23