

# ECLIPSE® 125

## NON-METALLIC EXTERNAL GEAR PUMP

**Eclipse pumps represent a dramatic advance in pump technology.**

Combining proven design principles with state-of-the-art engineered composites, it is the most safe, simple, and reliable pump on the market today. Service takes minutes, reducing process downtime and maintenance costs. It is commonly used for applications in industries such as chemical processing, petrochemical, and water treatment.



### Applications

- pH control
- odor control
- acids
- caustics



### Flow

up to 33 gpm (125 lpm)



### Pressure

up to 150 psi (10.3 bar)



### Temperature

up to 200°F (93°C)

\*with derated pressures

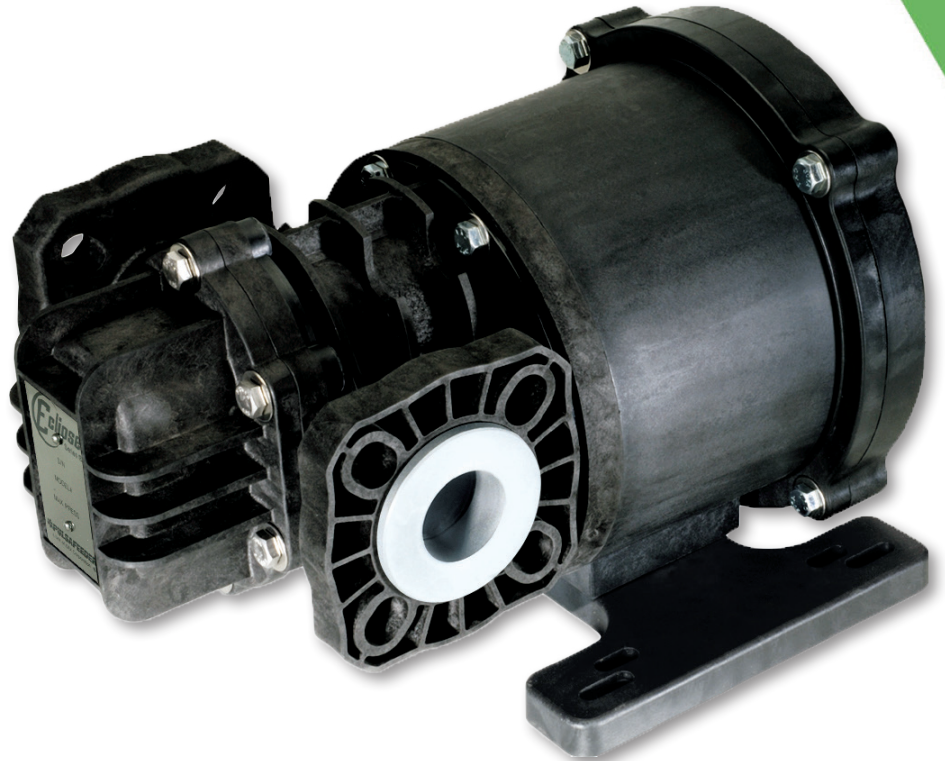

- No mechanical seals needed because of magnetically driven, engineered composite housings and gears
- Close coupled mounting eliminates cost and potential issues associated with pump and motor alignment
- Bi-directional and mounting in 45° increments

### Zero Leakage

- Fully encapsulated magnets
- Engineered composite fluoropolymer provides superior chemical resistance
- Zero emissions of hazardous or regulated chemicals

### Built for the harshest environments

- Ideal fit for many medium to highly corrosive liquids

### Ease of Maintenance

- Front pull-out design for quick and easy service
- Piping and electrical stay intact
- KOPkit® (Keep On Pumping kit) saves time and money
- Simplified orders and inventory
- Reduced downtime

### Controls

- Pulsafeeder RV Controller: Intelligent Motor Speed

# SPECIFICATIONS

<b>Gear type</b>	External spur gear
<b>Port size &amp; type</b>	1 1/2" ANSI 150# / DIN 32/40 Flanged
<b>Direction of rotation</b>	Bi-directional
<b>Theoretical displacement</b>	2.135 US gal / 100 Rev (80.82 cc / Rev)
<b>Max differential pressure</b>	150 psi (10.3 bar)
<b>Max allowable working pressure</b>	200 psi (14 bar)
<b>Max speed</b>	1750 RPM
<b>Max flow</b>	33 gpm (125 lpm)
<b>Viscosity</b>	10,000 cPs
<b>Max temp</b>	up to 200°F (93°C)*
<b>Min temp</b>	-40°F (-40°C)
<b>Bearing type</b>	Sleeve bearing
<b>Magnetic torque rating @ 68°F (20°C)</b>	668 in-lbs. (75.4 N-m)
<b>Magnetic temp rating</b>	300°F (149°C)
<b>Motor frame size</b>	NEMA, 143/145TC, 182/84TC, 213/15TC, IEC 100 B3/B14
<b>Pump weight</b>	44.7 lbs. (20.3 kg) less motor, approximate
<b>Standards</b>	NSF, ATEX, CE

\*with derated pressures

# MATERIALS OF CONSTRUCTION

<b>Base material</b>	PVDF
<b>Liner</b>	Carbon Reinforced PTFE
<b>Bearings</b>	Carbon (Graphite), Silicon Carbide (Graphite-Impregnated)
<b>O-rings</b>	Viton®, EPDM, or Perfluoroelastomer
<b>Shafts</b>	Alumina Ceramic
<b>Drive gear</b>	Carbon Reinforced PTFE
<b>Idler gear</b>	Carbon Reinforced PTFE
<b>Magnet</b>	Neodymium Encapsulated Virgin PTFE

# DIMENSIONS

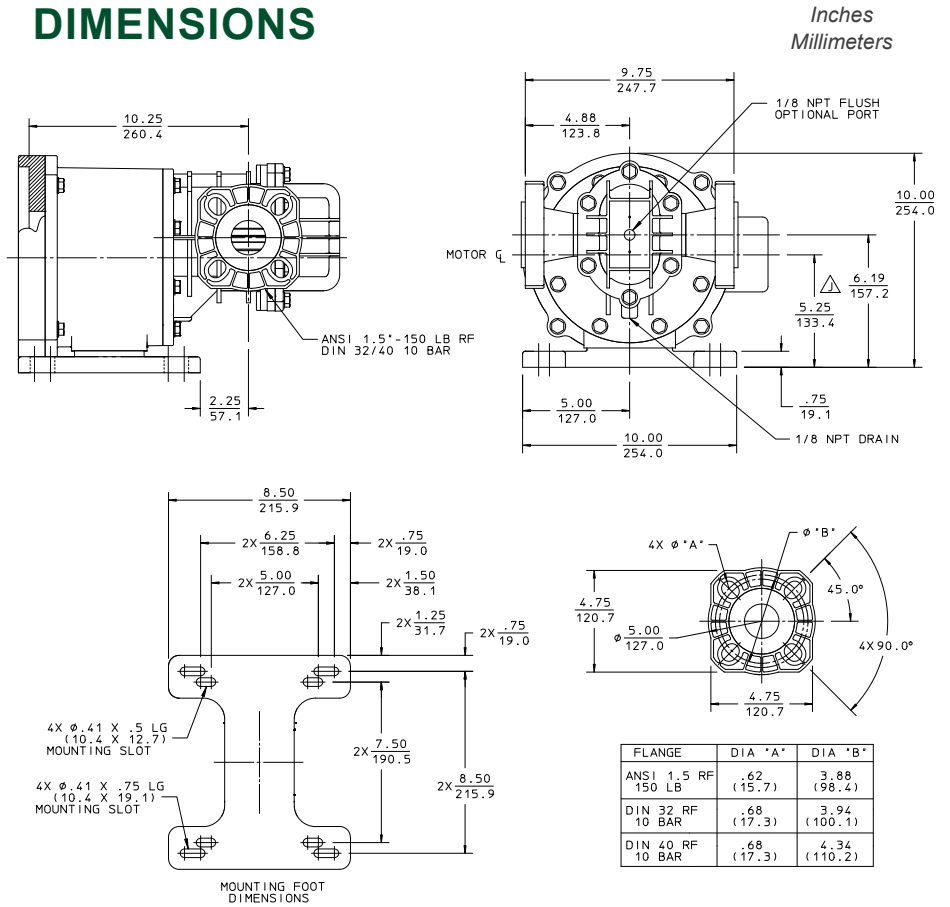

The dimensions given may differ depending on pump configuration.

# FLOW & PRESSURE ENVELOPE

(1 cPs, Specific Gravity 1.0)

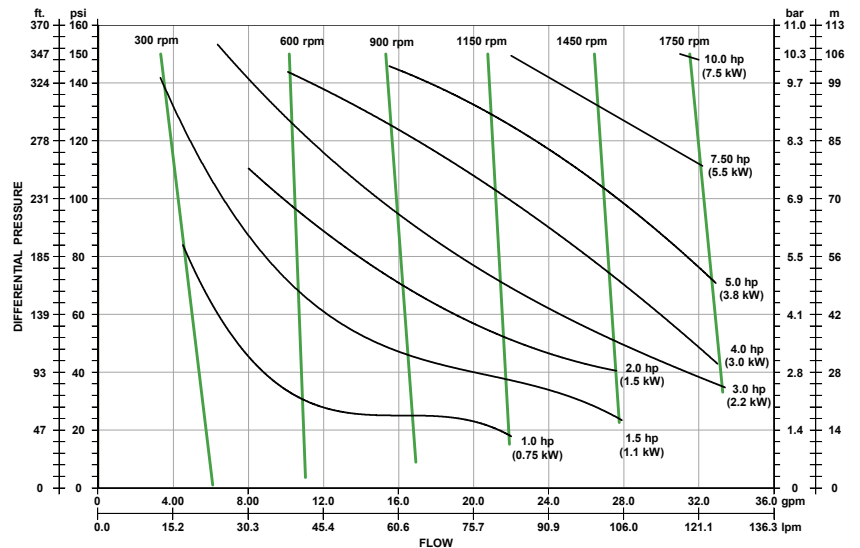

## Pulsafeeder, Inc.

2883 Brighton Henrietta Town Line Rd.

Rochester, NY 14623

Phone: +1 (585) 292-8000

pulsa@idexcorp.com • [pulsa.com](http://pulsa.com)

Pulsafeeder is an ISO 9001 Certified Company.

elc125spec\_Rev1022