



ECO®

CENTRIFUGAL PUMP

Installation Operation Maintenance Instruction

IMC-93 REV A



A Unit of IDEX Corporation
Manufacturers of Quality Pumps, Controls and Systems.

<https://pulsafeeder.com>

2883 Brighton-Henrietta Townline Rd.
Rochester, NY 14623 U.S.A.
ph. 585-292-8000; fax 585-424-5619

TABLE OF CONTENTS

	<u>PAGE</u>
GENERAL DESCRIPTION	2-3
INSTALLATION	4
OPERATION	4
MAINTENANCE	4-11
AVAILABILITY TABLE	12
CONSOLIDATED BILL OF MATERIALS	13-14
PUMP DRAWINGS	15-21
PUMP PERFORMANCE CURVES	22-23

PUMP MODEL # _____

GENERAL: CENTRIFUGAL PUMPS

Observe and follow the Standards of the Hydraulic Institute, particularly in the matter of installation.

1. Check all equipment for completeness against the order and for any evidence of shipping damage. Shortages or damage should be reported immediately to the carrier and to your pump supplier.
2. Pump installation site should be selected to provide easy access for routine maintenance and to protect the pump from damage by the elements or from leaks or drips from nearby process equipment.
3. Keep suction lines short, straight and of sufficient size to present minimum friction loss of head to the pump. Make sure there is sufficient suction supply, so that pump will not starve or run dry.
4. Use only full-bore ball valves or gate valves in the suction piping. If suction strainers are required, size them for minimum pressure drop and select those of a type that are easily cleaned.
5. Arrange all suction piping and fittings to prevent formation of air pockets. Make sure all joints are tight.
6. Flush and blow out all suction lines prior to making up to pump. Use nipples and unions, or spool pieces with flanged pumps, for ease of maintenance.
7. Do not spring piping, either suction or discharge, when mating up to pump. Use supports or hangers at intervals as required. When necessary, provide for thermal expansion and contraction so that no strain is placed upon the pump.
8. Check carefully alignment of pump and motor or drive system. Improper alignment is one of the most common

causes of seal problems, as well as a major cause of rapid bearing wear and eventual pump failure.

9. Check all bolts and nuts for tightness. Correct any conditions which could cause destructive vibration.
10. Where required, provide proper system for seal flush and/or drain. Observe any special instruction for packing lubrication.
11. If start-up screens are used, be sure they do not clog and starve suction. Start up screens should be removed prior to placing system into regular operation.
12. If flexible suction lines are used, be sure their selection and installation will prevent wall collapse and thus a starved suction condition.
13. When taking suction from a tank or vessel, avoid entry of sludge, solids, etc. into suction line by placing suction line inlet above maximum expected level of solids.
14. Where a by-pass system is used to control flow from pump, install "T" fitting in discharge line, control valve (manual or automatic), and pipe by-pass from valve back to suction vessel. If it is absolutely necessary to pipe by-pass back to pump suction line, or to pipe relief valve outlet back to pump suction line, point of entry should be at least 10 pipe diameters away from suction inlet, and provision for cooling made in the event of excessive heat build-up through fluid recirculation.
15. Where pumped fluids may solidify, crystallize, precipitate etc., provision should be made to thoroughly flush pump and piping during periods of shutdown. Pay particular attention to proper flushing of seal area.

CAUTION: Before performing any maintenance, be sure to flush pump thoroughly with a neutralizing medium to prevent possible injury to personnel.

MECHANICAL SEALS

Two basic seal types are offered as standard: internal, and double seal. In addition, a patented "wet seal" design is available with certain centrifugal pumps which prevents seal burn out when running "dry" for periods up to 2 1/2 hours, depending on the application.

All mechanical seals require cooling and lubrication. The "wet seal" design is such that these requirements are met automatically after the pump has been initially primed. However, for long and trouble free seal life:

- A. Do not run pump dry. Make sure pump is primed, suction is not starved, sufficient NPSH is available and your system is such that seal surfaces are wet. If a seal flush system is used, make sure that it is operating while the pump is operating.
- B. Keep abrasives out of the seal area. Dirty flush streams, whether piped from the pump discharge or from a separate source, will destroy the rotating and stationary seal mating surfaces.
- C. Make sure pump and driver are properly aligned. Cocked seal mating surfaces will not function. By the same token, excessive vibration will prevent proper seal function and cause early failure.
- D. Determine that seal materials of construction are compatible with pumped fluid. Be sure to check this when changing application.

INSTALLATION

1. Install according to instructions given in the "General" section.
2. To check system operation, installation of pressure gauges in the suction and discharge lines, close to the pump, is recommended.
3. Looking at the pump drive shaft, proper rotation is clockwise. An arrow is cast into the front housing.

OPERATION

1. Prior to operation, recheck the suction system to be sure NPSH available to the pump is adequate. Make sure all suction piping is air tight and clean. Turn pump over by hand. If any mechanical binding or other trouble is detected, determine cause and correct. Check that electrical service to motor agrees with name plate ratings. Jog to check rotation and reconnect motor if necessary.
2. Priming. All centrifugal pumps must be primed before operation and any air must be vented from the casing. To prime initially, fill priming chamber (approximately 15 ounces) with appropriate fluid. If foot valves are used, the valve should be of the flapper type and sized to present minimum friction loss. Threaded and plugged vents are provided on all centrifugal pumps to aid in priming and venting.
3. Check mechanical seal flush arrangements, where used. Flush streams, whether from pump discharge or a separate source must be clean. Where a double seal is used, flush stream to seal area must operate at 5 to 10 psi above pump discharge pressure.
4. Centrifugal pumps can operate against a closed discharge valve without overloading the drive. However, heat builds up very quickly. Do not operate

against a closed discharge valve for more than one minute. Where requirements dictate operating close to shut off, check for excessive temperature rise in pump chamber and seal area. A by-pass system is recommended rather than a heavily throttled pump.

5. Start pump with discharge valve slightly open and check for proper operation. Check flush streams for proper operating pressure and flow. If pump seal area runs hot, or if bearings (pedestal mounted pumps) run hot, shut down and determine cause.

MAINTENANCE

CAUTION: Before performing any maintenance requiring pump disassembly, be sure to flush pump thoroughly with a neutralizing fluid to avoid harm to personnel.

1. All centrifugal pumps have the pump shaft coupled to the drive shaft by means of a telescopic fit. The pump shaft is bored to receive the drive shaft, and, when adjusted for impeller clearance and proper seal setting, is secured to the drive shaft with two set screws. On motor mounted units, the pump shaft telescopes directly over the motor shaft and dog point set screws hold the pump shaft in position. On pedestal mounted units the pump shaft telescopes over the pedestal shaft which is supported by two sealed ball bearings in the pedestal. Cup point set screws secure the two shafts. With the pump shaft supported and driven in this manner, it is important for proper operation, particularly in the seal area, that the drive shaft runs true. Maximum drive shaft run out, mounting surface run out, and eccentricity in relation to the mounting rabbet must be within NEMA standard for 56C face motors.
2. When changing a pump from one service to another be sure to check that

all wetted parts of the pump (including seals) are compatible with the fluid to be handled and that the motor is of sufficient horsepower to produce non-overloading operation throughout the curve, particularly when the fluids are of different specific gravity.

3. Centrifugal pumps are designed to handle clear fluids only, at viscosities no greater than 50 cps. No centrifugal pump should be run dry. Damage to seal mating surfaces will result. In the case of the C-10 pumps equipped with a double mechanical seal, the pump itself may be run ~ "dry" as long as the flush stream to the seal area is maintained in order to keep the seal surfaces wet. "Wet Seal" pumps can run dry intermittently, after once being full.
4. The significant model number stamped on the pump name plate, identifies the pump type, the seal arrangement, and other details. Refer to the significant model number chart if you are unsure of exactly what type of pump or seal you have. Always refer to the full model number in any correspondence with the factory. A consolidated parts list for pumps is included in this manual and it shows a list of recommended spares. Always order by complete part number and include descriptions. Do not use item number on drawings to order parts.
5. Mechanical Seal Design. Single mechanical seals of 316 stainless steel construction use a stationary seal head mounted in the rear housing and a rotating seal seat fixed to the shaft. Where basic material of construction is Alloy C, the seal seat is stationary, while the single seal head rotates, driven by a collar fixed to the shaft.

A double seal configuration is available only with the pedestal mounted pump. Seal seats are stationary and the double seal head rotates with the shaft. Seal seat metallurgy is that of the pump

itself (316SS, Alloy C) while standard construction for metallic parts of the seal head is 316SS since only the flush stream contacts these parts. As an option, double seal heads are available in Alloy C.

7. Mechanical Seal Inspection.

When seal heads and seats are removed, they should each be examined carefully.

- A. Inspect seats for scoring, non-concentric wear lines or other damage. On stationary seal seat pumps, check seat ID for damage by shaft.
 - Seal seats with ceramic inserts showing damage must be replaced.
 - Solid metallic seal seats showing only light scratches or marks may be relapped. lapping standards are smooth and flat to 3 helium light bands.
- B. Inspect seal faces for cracks, chips, scoring or other damage.
 - Seal heads with damaged seal faces must be replaced or a new seal face fitted.
 - Seal heads with smooth and shiny but worn faces must be repaired or replaced if wear is such that face does not project at least .060 inches from metal casing when spring is fully compressed. Minor scratches may be readily polished out.
 - Seal heads must be repaired or replaced if TFE wedge has been damaged either when removed from shaft or from other causes.

When reinstalling shaft mounted seal heads, make sure set screws do not protrude into ID of head and thus damage shaft. Check face of new or refurbished seal head for freedom of movement by carefully compressing into seal head and then releasing. When refitting

seal head over shaft, use a "bullet" to introduce seal head onto shaft to prevent damage to the TFE wedge.

When reinstalling solid ceramic seal seats, make absolutely sure there are no burrs or any foreign matter in the shaft diameter or shoulder where the seat will locate. Any such material can cause uneven forces to act on the seal seat when compression is applied during take up of the impeller retaining bolt, and the seat will crack. During installation, rotate the seal seat back and forth several times in its proper location to assure proper fit. Then install impeller. Do not overtighten impeller bolt.

DISASSEMBLY AND REASSEMBLY (Refer to Drawing SD-2421)

Disassembly

1. Remove housing bolts, nuts, and washers, and remove front housing or pull assembly away from rear housing.
2. Remove housing gasket.
3. Remove impeller retaining bolt, impeller drive collar, and impeller.

4A. For Single Seal, 316SS Pumps

- a. Carefully slide seal seat and seal seat O-ring from shaft, exposing cartridge seal head.
- b. Proceed with necessary seal maintenance for cartridge type seals.

4B. For Wet Seal Pumps

- a. Remove slinger and spacer from shaft.
- b. Proceed as for single seal, 316SS pump noted in Paragraph 4A above.

4C. For Single Seal Alloy C Pumps (Refer to Drawing SD-2424)

- a. Remove seal drive collar with integral pin, and carefully withdraw seal head.
- b. Rear housing containing seal seat and seal seat O-ring may be withdrawn over pump shaft after removing nipple.
- c. Proceed with necessary seal maintenance for stationary seat single seals.

4D. For Double Seal Pumps (Refer to Drawing SD-2422)

- a. Remove flush stream connections and nipples.
- b. Loosen pump shaft set screws and withdraw rear housing with shaft.
- c. Loosen seal head set screws with Allen wrench inserted through tapped hole for nipple. Rotate shaft to expose all set screw sockets. Withdraw shaft.
- d. Carefully remove seal seat retaining rings on outboard side of each seal seat.
- e. Proceed with necessary seal maintenance for double seals.

Reassembly

1. Prior to reassembly, clean all parts and replace any whose condition would impair performance. Bent shafts, corroded impeller drive collars, etc., must be replaced. Inspect TFE shaft flange and replace where necessary. Check drive shaft for run-out and end play.

2. Rotating seal heads depend upon the compressed fit of a TFE wedge against the pump shaft. Any damage to this TFE wedge when installing the seal head can cause leakage along the shaft. Any damage to this TFE wedge when installing the seal head can cause leakage along the shaft. To prevent damage, use a "bullet" to introduce the seal head over shaft shoulders and protect the wedge.

3A. For Single Seal, 316SS Pumps

- a. Fit pump shaft over drive shaft, but do not fully tighten set screws.
- b. Carefully reinstall rear housing with new or refurbished seal head and TFE shaft flange. Align housing to accept dowel pin located in pedestal or motor mounting bracket. Make sure housing fits flush and square into rabbet of pedestal or bracket.
- c. Slip new or refurbished seal seat and seal seat O-ring over shaft, with O-ring and O-ring groove facing impeller area.
- d. Refit impeller, together with impeller drive collar and retaining bolt.
- e. Carefully tighten impeller retaining bolt, thereby compressing seal seat against shaft shoulder and containing seal seat O-ring. Flats are provided on the pump shaft for wrenching.
- f. Set impeller-to-rear housing clearance at .017 inches and tighten pump shaft set screws.
- g. Install new housing gasket.
- h. Refit front housing and housing bolts, nuts, and washer.

- i. Reinstall nipples, plug. Turn pump over by hand. If bending or other trouble is detected, determine cause and correct.

3B. For Wet Seal Pumps

- a. Proceed as in 3A above, but prior to refitting impeller, install spacer on shaft and then slinger. Be sure end surface of spacer bearing on seat O-ring is square and smooth. Concave side of slinger cup should point toward seal head.

3C. For Single Seal Alloy C Pumps (Refer to Drawing SD-2424)

- a. Be sure rear housing is clean, particularly in the counter bore where the seat will lie. Protect seat face when pressing in and make sure seat is square with rear housing centerline and not cocked.
- b. Fit pump shaft over drive shaft, but do not fully tighten set screws.
- c. Carefully reinstall rear housing with new or refurbished seal seat, new seal seat O-ring and new TFE shaft flange. Align housing to accept dowel pin.
- d. Using a "bullet" whose OD matches the major OD of the pump shaft and whose open end rests on the shaft shoulder, carefully slide the seal head onto the shaft until the seal face bears on the seal seat.
- e. Remove "bullet" and reinstall seal drive collar so that pin in collar engages one of the holes in the rear of the seal head.
- f. Proceed as in Step "D" Paragraph 3A above to reinstall impeller and

remaining parts, and to set impeller clearance.

3D. For Double Seal Pumps (Refer to Drawing SD-2422)

- a. Careful installation of new or refurbished seal seats is the key to successful operation of the double mechanical seal.
- b. Be sure all parts are clean, that there are no nicks or burrs on pump shaft and that inboard seal seat retaining rings are properly located and fitted, and square and true in the rear housing. Some models have a shoulder at either end of the rear housing instead of inboard retaining rings. Be sure that seal seat O-rings are not damaged in any way.
- c. Install impeller-side seal seat with lapped face toward inboard retaining ring. Press evenly and carefully to maintain squareness of seal seat with housing centerline. Install outboard retaining ring in groove in housing, being sure not to cock seal seat.
- d. Loosen set screws in seal head and check to make sure they do not project into seal bore. Position outboard seal seat on pump shaft with lapped face toward impeller end of shaft, and using a bullet, position seal head on shaft. Remove bullet and carefully insert shaft with head and seal seat into pump rear housing, passing impeller end of shaft through hole in inboard seal seat. Make sure lapped surface of inboard seal seat (facing away from impeller end) is not damaged.
- e. Place rear housing, with impeller side down, in arbor press, leaving

sufficient space under rear housing. Carefully compress entire shaft assembly downward. With arbor press, ram bearing squarely on motor end of shaft.

- f. With pressure maintained on shaft, fit outboard retaining ring in groove.
- g. Carefully mount entire subassembly onto pedestal, sliding pump shaft over pedestal shaft, fitting rear housing into rabbet of pedestal, and aligning dowel pin hole in housing with dowel pin.
- h. Set impeller-to-rear housing clearance at .017 inches and tighten pump shaft set screws. Tighten seal head set screws through tapped hole in rear housing, rotating shaft to allow access to all screws.
- i. Refit front housing gasket, front housing, and housing nuts, bolts, and washers. Reinstall flush stream nipples.
- j. Turn pump over by hand and correct any binding or other indications of improper assembly.

Pump Pedestal (Refer to the following drawings: SD-2421, SD-2418, SD-2419).

Pump pedestal may be serviced while pump and pump shaft are removed.

1. Remove bearing cap and pull drive shaft with bearings from pedestal.
2. Check bearings for wear and replace if necessary. When pressing bearings on shaft, press only on inner race.
3. Drain old oil from pedestal and flush clean.
4. Remount shaft and bearings and replace

rear bearing cap. Test for freedom of rotation, and for run out and end play.

5. Refill to proper level with clean oil.

MECHANICAL SEAL MAINTENANCE DETAILS

Cartridge Seal

(Refer to Drawing SD-2381-2)

This seal is used in all centrifugal pumps as a single internal seal where the basic material of construction of the pump is 316SS.

The seal head is stationary and the seal seat rotates. The seal face may be carbon or TFE. The seal seat is either Alloy 20, Alloy 20 with a ceramic insert, or in some cases solid ceramic.

The seal head is a press fit into the housing while the seal seat is clamped to the pump shaft after the impeller retaining bolt is properly tightened. "Setting" the seal is accomplished by moving the pump shaft, with the seal seat, telescopically over the drive shaft to the proper location, thereby compressing the seal face and also setting proper clearance between the impeller and the housing. Once the shaft is properly positioned, set screws are tightened to hold it there.

For proper seal functioning, the following conditions must be present:

- a. The seal face must be smooth, free of cracks or ridges, and free of any score marks particularly those which emanate radially.
- b. The seal face must be free to move in compression into the retainer. Any dirt or other matter which restricts free travel of the face when pressed against the spring can prevent the face from running properly against the seat.
- c. The seal face must not be worn to such a degree that it can not make proper compressive contact against the seal seat. Drawing SD-2381-2 shows the maximum allowable wear.

- d. The seal seat must be in equally as good a condition as the seal face.
- e. The seal seat must be perpendicular to the shaft axis and run true. A bent shaft will prevent proper sealing. Burrs, dirt, or other matter in the shaft area where the seal seat locates can prevent true perpendicularity and can cause a solid ceramic seat to crack.
- f. The seal seat O-ring must be properly positioned and compressed to make an effective seal along the shaft. O-rings should not be reused. The side of the seat containing the O-ring must always face toward the impeller.

If it is necessary to replace the cartridge seal, proceed as follows:

- a. Place the housing, impeller-side downward, in an arbor press, allowing necessary clearance for the seal head to pass below.
- b. Using a soft rod (brass or wood) properly sized so as not to mar the bore of the housing where the seal head fits, press out the seal head.
- c. When fitting a new seal head, make sure the housing bore is clean, and free of nicks, burrs or scratches. Lubricate the new seal head with a TFE suspensoid or other non-contaminating lube.
- d. With the housing reversed in the arbor press, position the new seal head carefully and press it home until the retainer shoulder bottoms on face of the housing bore. A wood or brass rod must be used which bears on the outer ring of the retainer. Do not press on the inner ring.

Stationary-Seat Single Seal
(Refer to Drawing SD-2424)

This seal is used on pumps as a single internal seal where the basic material of construction is Alloy C.

The seal seat is stationary and the seal head rotates. The seal face may be carbon or TFE. The seal seat is solid Alloy C, or the appropriate alloy with a ceramic insert. The seal seat is pressed into the rear housing. The seal head floats axially on the shaft and is driven by a pin attached to a collar which is clamped to the pump shaft after the impeller retaining bolt is properly tightened. "Setting" the seal is accomplished by moving the pump shaft to the proper location thereby compressing the seal face and also setting proper clearance between the impeller and the rear housing. Once the shaft is properly positioned, set screws are tightened to hold it there.

The same general precautions are necessary for proper operation of this seal as are for the cartridge seal described above. A seal face is too worn for further use when it does not project at least .080" from the edge of the retainer.

Sealing along the shaft with this seal is accomplished by the lip of the TFE wedge contained within the seal head. If this lip is damaged during its passage over the shaft, it will not seal. Always use a "bullet" to ease the installation of the seal head over the step on the shaft.

To remove the seal seat, place the rear housing, impeller-side downward, in an arbor press. Using a properly sized wood or brass rod, press the seal seat and O-ring out of the housing. Condition of the seal seat may now be closely examined and it may permit refurbishing.

Turn the housing over and carefully position the seal seat with O-ring in the bore. A TFE suspensoid or similar noncontaminating lubricant aids. Using a properly sized tool which bears only on the seat periphery and

not on the lapped surface, press the seat home squarely and firmly until it bottoms on the step in the bore. A piece of 3/4" brass pipe, squared off and free of burrs is ideal for this tool.

Prior to reinstallation of the seal head, be sure the face moves freely under compression in the retainer and that the lip of the TFE wedge is not damaged.

Double Seal
(Refer to Drawing SD-2422)

The double mechanical seal is available for use only with pedestal mounted pumps.

The seal head is positioned between two stationary seal seats and rotates with the shaft. The seal seats are always of the basic metallurgy of the pump itself, except that seats are of Alloy 20 in 316SS pumps. Metallic parts of the seal head are 316SS as standard, since the seal head is wetted only by the flush stream. As an option, seal heads of Alloy C metallurgy can be furnished.

The seal seats are a press fit into the rear housing and are positioned there by retaining rings on either side of each seat. Some models have a shoulder in either end of the housing bore. Spacing of the seal seats is such that proper "setting" of the seal is assured, since the seal head is allowed to float on the shaft until proper impeller clearance is set by moving the pump shaft telescopically over the drive shaft. Once this clearance is set, shaft set screws are tightened, and then the seal head set screws can be tightened so as to drive the seal head.

The general precautions noted above for proper functioning of single seals also apply here. However, a seal flush must always be present when the double seal is running, since this flush both cools and lubricates the seal mating surfaces. The flush stream must be absolutely clean and introduced at a pressure about 5 to 10 psi higher than discharge pressure.

Referring to Drawing SD-2422, it can be seen

that static sealing is maintained by the O-ring seals along the OD of the seal seats and by the lips of the opposing TFE wedges in the seal head along the shaft. Damage to or improper installation of either of these two static sealing systems will cause leakage. The dynamic seal is obtained by proper fit, compression and condition of the rotating carbon seal faces in the seal head and the mating portion of the seal seats. Excessive wear of the seal faces, hang-up in the springs caused by dirt or other reasons, lack of parallelism between seats and faces - all can cause malfunction as well as the scoring, pitting, cracking, etc., discussed generally above. Seal faces, although appearing in good condition, are too badly worn when a measurement from face to face is less than 1.40 inches. When excess wear produces a measurement less than this, proper compression of seal faces will not result when seal head is installed.

Assuming a proper flow of cool, clean flush liquid, the major cause of double seal problems is misalignment of the seal seats with the seal faces. Seal seats must be perpendicular to the shaft and thus parallel with the seal faces. Rough handling during shipment, or even during installation can cause misalignment. A bent pump shaft, a pedestal shaft not running true, or worn pedestal bearings can also cause misalignment.

One of the easiest ways to check proper double seal operation is to run the pump "dry" with only the flush stream connected to the pump and operating. Leakage between the drive-side seal face can be seen along the pump shaft or leakage around the seal O-ring can be seen at the end of the rear housing. Leakage at the impeller side seal can be detected by checking for a fine spray coming out of the pump discharge port. Removing the pump front housing and impeller will allow determination of the cause, either at the seal face or at the seat O-ring.

**ECO CENTRIFUGAL PUMP
SIGNIFICANT MODEL NUMBER SYSTEM AND AVAILABILITY TABLE**

 - -

POSITION NO.: 1 2 3 4 5 6 7 8

<u>POSITION 1</u> SERIES C = CENTRIFUGAL PUMP	
<u>POSITION 2</u> PUMP SIZE	10
STANDARD IMPELLER DIA TYPE SUCTION	3.75" END
<u>POSITION 3</u> AVAILABLE PUMP METALLURGIES AND TYPE PORT CONNECTION	
A = 316SS FNPT	X
C = ALLOY C FNPT	X
K = 316SS FBSPT	X
M = ALLOY C FBSPT	X
<u>POSITION 4</u> IMPELLER TYPE	
O = OPEN	X
<u>POSITION 5</u> IMPELLER DIAMETER (1,2 AND 3 ARE REDUCED DIAMETER IMPELLERS)	
S = IMPELLER STANDARD DIA	X
1 = IMPELLER 3.50 DIA	X
2 = IMPELLER 3.25 DIA	X
3 = IMPELLER 3.00 DIA	X
<u>POSITION 6</u> SEAL ARRANGEMENT	
D = Double Seal: CBN Face, Metallic Seat	X
E = Double Seal: CBN Face, Silicon CBD Seat	X
K = Single Seal: CBN Face, Silicon CBD Seat	X
S = Single Seal: CBN Face, Metallic Seat	X
T = Single Seal: TFE Face, Silicon CBD Seat	X
U = Single, Wet Seal: CBN Face, Metallic Seat	X
V = Single, Wet Seal: TFE Face, Silicon CBD Seat	X
W = Single, Wet Seal: CBN Face, Silicon CBD Seat	X
<u>POSITION 7</u> MOUNTING ARRANGEMENTS	
D = Directly Mounted on Motor	X
P = Pedestal Mounted	X
<u>POSITION 8</u> OPTIONS	
X = Special	X

C10 CENTRIFUGAL PUMP CONSOLIDATED B/M

SECTION: D / C 10
PAGE: 100
DATE REV.: 04/18/25
SUPERSEDES: 01/06/16

		STANDARD PUMP MATERIAL				ITEM
		316 SS (A) OR (K)		ALLOY C (C) OR (M)		
DESCRIPTION	QTY	PART NUMBER	MATERIAL	PART NUMBER	MATERIAL	

POSITION 3 STANDARD PUMP - NON-VARIABLE COMPONENTS

HOUSING, FRONT FNPT	1	100003	316 SS	100001	ALLOY C	4
HOUSING, FRONT FBSPT		100004	316 SS	100007	ALLOY C	4
# GASKET, HOUSING	1	101101	TFE	101101	TFE	6
HOUSING, REAR SGL SEAL	1	100112	316 SS	100105	ALLOY C	16
HOUSING, REAR DBL SEAL		100113	316 SS	100115	ALLOY C	16
HOUSING, REAR SGL, WET SEAL		100118	316 SS	----	----	16
# SHAFT, PUMP SGL SEAL	1	100416	316 SS	100418	ALLOY C	21
# SHAFT, PUMP DBL SEAL		100424	316 SS	100426	ALLOY C	21
# SHAFT, PUMP SGL, WET SEAL		100428	316 SS	----	----	21
# BOLT, IMPELLER RETAINING	1	W770459-316	316 SS	W770459-HC0	ALLOY C	7
# COLLAR, IMPELLER DRIVE	1	56702	ALLOY 20	56703	ALLOY C	8
PIN, HOUSING	1	40801	316 SS	40801	316 SS	17
PLUG, 1/8" NPT	*4	W772585-017	316 SS	W772585-020	ALLOY C	5
NUT, HOUSING BOLT	4	W771214-188	188 SS	W771214-188	188 SS	1
BOLT, HOUSING	1	W770417-188	188 SS	W770417-188	188 SS	3
BOLT, HOUSING	3	W770415-188	188 SS	W770415-188	188 SS	3
WASHER, HOUSING BOLT	4	W771107-188	188 SS	W771107-188	188 SS	2
NAMEPLATE	1	51201	188 SS	51201	188 SS	24
NAMEPLATE WET SEAL		51205	188 SS	----	----	24
4-07X .18 SCREW DRIVE	2	W77100-188	188 SS	W77100-188	188 SS	--

POSITION 4 & 8 IMPELLER TYPE AND OPTIONS (INTENTIONALLY LEFT BLANK)

POSITION 5 IMPELLER DIAMETER

S	IMPELLER, OPEN 3.75 DIA	1	100215	316 SS	100218	ALLOY C	9
1	IMPELLER, OPEN 3.50 DIA		100224	316 SS	100229	ALLOY C	9
2	IMPELLER, OPEN 3.25 DIA		100221	316 SS	100230	ALLOY C	9
3	IMPELLER, OPEN 3.00 DIA		100220	316 SS	100231	ALLOY C	9

POSITION 6 SEAL ARRANGEMENT

DOUBLE SEAL (AVAILABLE PEDESTAL MOUNTED PUMP ONLY)							
D	# RETAINING RING, SEAL SEAT	2	106009	ALLOY 20	106007	ALLOY C	38
	# SEAL HEAD ASSEMBLY	1	27092	316 / CBN	27092	316 / CBN	37
	# SEAL SEAT W/ O-RING (TFE)	2	51063	316 SS	51062	ALLOY C	39
E	# RETAINING RING, SEAL SEAT	2	106009	ALLOY 20	106007	ALLOY C	38
	# SEAL HEAD ASSEMBLY	1	27092	316 / CBN	27092	316 / CBN	37
	# SEAL SEAT W/ O-RING (TFE)	2	51068	SICBD	51068	SICBD	39

*COMPONENT QUANTITY MAY BE CUMULATIVE OVER ENTIRE B / M

DWG: C10DP100

DENOTES RECOMMENDED SPARE PART

C10 CENTRIFUGAL PUMP CONSOLIDATED B/M

SECTION: D / C 10
PAGE: 101
DATE REV.: 01 / 06 / 16
SUPERSEDES: 02 / 06 / 13

DESCRIPTION	QTY	STANDARD PUMP MATERIAL				ITEM
		PART NUMBER	MATERIAL	PART NUMBER	MATERIAL	
			316 SS (A) OR (K)		ALLOY C (C) OR (M)	

POSITION 6 SEAL ARRANGEMENT (CONTINUED)

SINGLE SEAL							
COMMON PART	DESCRIPTION	QTY	PART NUMBER	MATERIAL	PART NUMBER	MATERIAL	ITEM
	FLANGE, DRAIN	1	51601	TFE	51601	TFE	19
K	# SEAL HEAD ASSEMBLY	1	27146	316 / CBN	A27082	HCO / CBN	37
	# SEAL SEAT W/ O-RING (TFE)	1	51067	SICBD	51066	SICBD	39
S	# SEAL HEAD ASSEMBLY	1	27146	316 / CBN	A27082	HCO / CBN	37
	# SEAL SEAT W/ O-RING (TFE)	1	51065	ALLOY 20	51064	ALLOY C	39
T	# SEAL HEAD ASSEMBLY	1	27147	316 / TFE	A27084	HCO / TFE	37
	# SEAL SEAT W/ GASKET (TFE)	1	51067	SICBD	51066	SICBD	39

SINGLE, WET SEAL

COMMON PART	DESCRIPTION	QTY	PART NUMBER	MATERIAL	PART NUMBER	MATERIAL	ITEM
COMMON PART	FLANGE, DRAIN	1	51601	TFE	----	----	19
	SLINGER	1	100430	316 SS	----	----	12
	SPACER, SLINGER	1	100429	316 SS	----	----	13
U	# SEAL HEAD ASSEMBLY	1	27146	316 / CBN	----	----	37
	# SEAL SEAT W/ O-RING (TFE)	1	51065	ALLOY 20	----	----	39
V	# SEAL HEAD ASSEMBLY	1	27147	316 / TFE	----	----	37
	# SEAL SEAT W/ GASKET (TFE)	1	51067	SICBD	----	----	39
W	# SEAL HEAD ASSEMBLY	1	27146	316 / CBN	----	----	37
	# SEAL SEAT W/ GASKET (TFE)	1	51067	SICBD	----	----	39

POSITION 7 MOUNTING ARRANGEMENT

COMMON PART	DESCRIPTION	QTY	PART NUMBER	MATERIAL	PART NUMBER	MATERIAL	ITEM
D	BRACKET, PUMP	1	100301	CI	100301	CI	23
	BOLT, PUMP BRACKET	4	W770425-188	188 SS	W770425-188	188 SS	22
	SET SCREW, 1/4" DOG PT	2	W771004-116	17-4PH	W771004-116	17-4PH	34
	PLUG 1/8" NPT "WET SEAL ONLY"	*1	W772585-017	316 SS	W772585-020	ALLOY C	15
	SHIPPING SUPPORT	1	Y9900300-000	PLASTIC	Y9900300-000	PLASTIC	--
	GUARD ASSY,PUMP SHAFT	1	Y1600600-000	ABS	Y1600600-000	ABS	--
	SCREW, GUARD ASSEMBLY	4	W208894-STL	STL	W208894-STL	STL	--
P	SET SCREW, 1/4" CUP PT	2	W771004-112	STL	W771004-112	STL	20
	PLUG, 1/8" NPT "WET SEAL ONLY"	*1	W772585-017	316 SS	W772585-020	ALLOY C	15
	PEDESTAL ASSEMBLY**	1	A103203	CI	A103203	CI	--

**PEDESTAL ASSEMBLY CONSISTS OF:

DESCRIPTION	QTY	PART NO.	MATERIAL	ITEM
OIL CUP	1	A53801	STL	32
SHAFT, PEDESTAL-CPLG DIA .75	1	100435	STL	28
PEDESTAL	1	103203	CI	31
OIL SEAL	2	103402	RUBBER	35
KEY	1	W773098-007	STL	33
FITTING, AIR VENT	1	27219	STL	36
GASKET	3	52400	PAPER	27
CAP, BEARING	1	53302	CI	26
BEARING, FRONT	1	53901	STL	30
BEARING, REAR	1	53900	STL	29
SCREW, BEARING CAP	4	54101	188 SS	25

*COMPONENT QUANTITY MAY BE CUMULATIVE OVER ENTIRE B / M

DENOTES RECOMMENDED SPARE PART

DWG: C10DP101

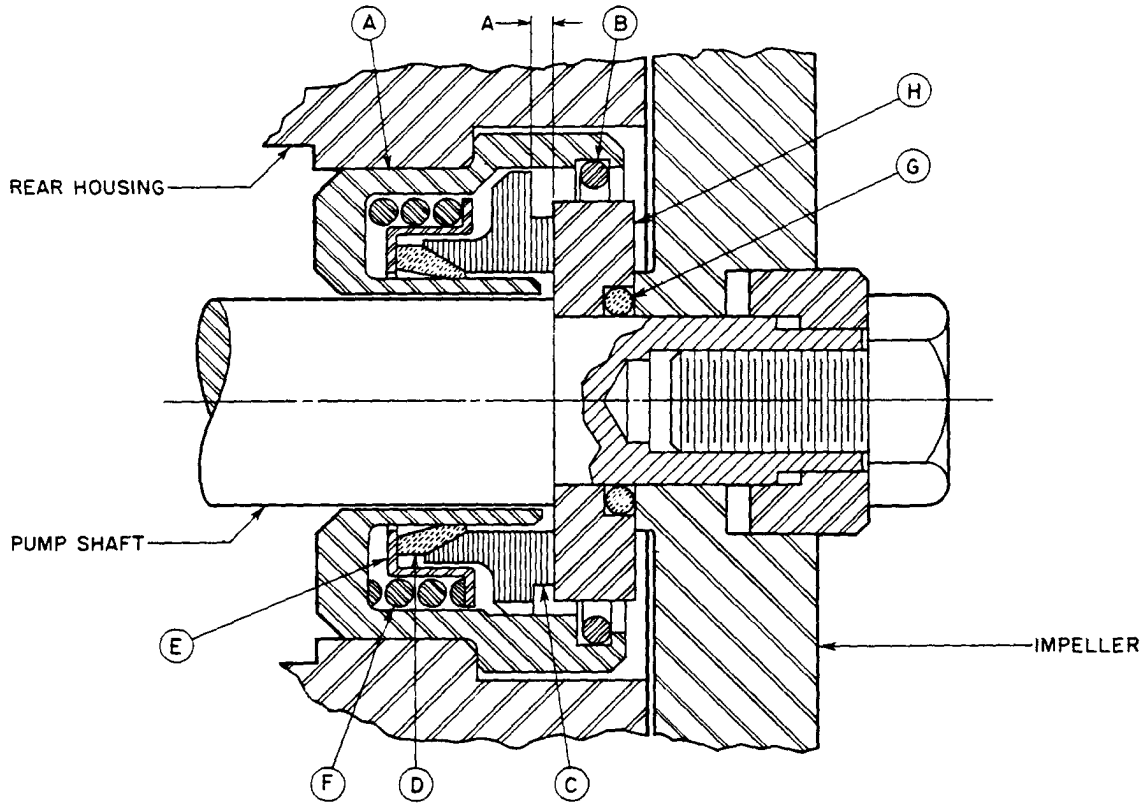

37	BASIC SEAL HEAD MATERIAL	
	SEAL HEAD ASSEMBLY	
	ITEM	DESCRIPTION
	A	RETAINER
	B	RETAINER RING
	C	SEAL FACE
		OR CARBON TFE
	D	WEDGE
E	FERRULE	
F	SPRING	

SEAL HEAD ASSEMBLIES SHOWN ABOVE USED WITH PARTS SHOWN BELOW

39	G	O-RING, SEAT	
	H	SEAL SEAT	
		OR	METALLIC
			CERAMIC

NOTES:

1. REPLACE SEAL HEAD WHEN DIMENSION MARKED *A* BECOMES .010" OR LESS.

ECO 

SINGLE SEAL (K,S AND T)
316SS
C10 CENTRIFUGAL PUMPS

D	03-05-93	CHANGE TITLE	P.W.
C	11-01-91	UPDATE CHART	P.W.
B	2-24-77	DELETED P/N A-27046	R.R.
A	6-1-76	CHANGED P/N WAS , A-27061 & 27044-2	R.R.
NO.	DATE	REVISIONS	BY

DWN. BY: RCS
DATE 9-25-86

SD-2381-2

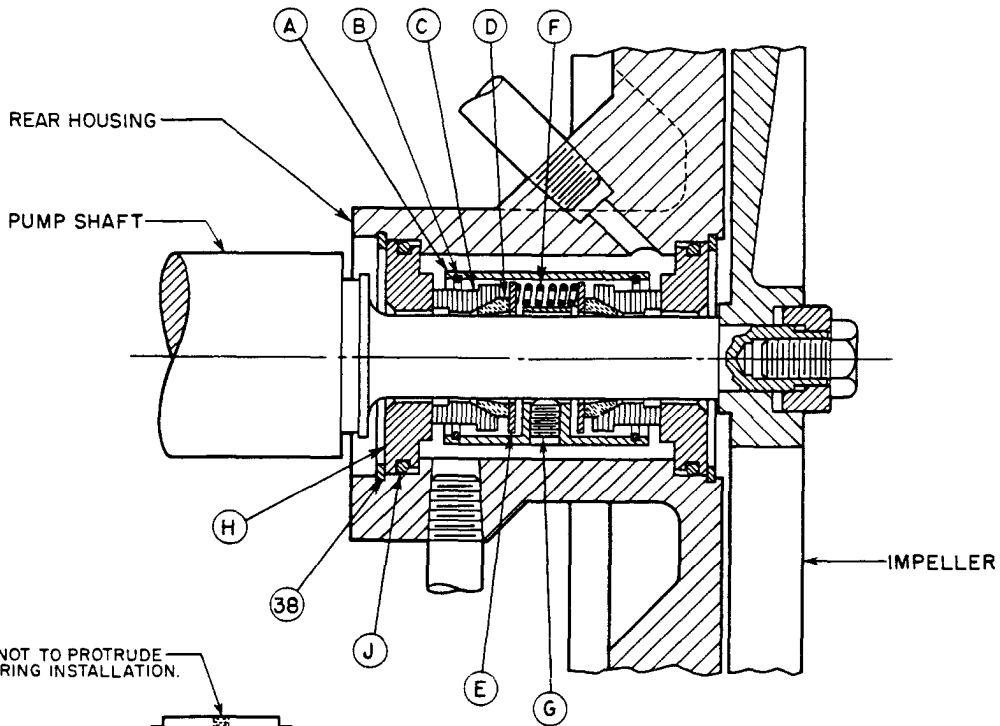

SET SCREWS NOT TO PROTRUDE INTO BORE DURING INSTALLATION.

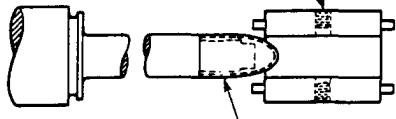

CARE SHOULD BE TAKEN TO PREVENT DAMAGE TO WEDGE WHEN INSTALLING SEAL HEAD. IT IS RECOMMENDED THAT A 'BULLET' BE USED.

BASIC SEAL HEAD MATERIAL

SEAL HEAD ASSEMBLY	
ITEM	DESCRIPTION
37	A RETAINER
	B RETAINING RING
	C SEAL FACE - CARBON
	D WEDGE
	E DISC
	F SPRING
	G SET SCREW

39	H SEAL SEAT
	J O - RING, SEAT
38	-- RETAINER, SEAT

ECO  **Pulsafeeder**

DOUBLE SEAL (D AND E)
C10 CENTRIFUGAL PUMPS

3/93 C CHANGE TITLE

11/91 B UPDATE CHART

11/85 A DELE ASSY CMPNT P/N

DWN. BY: MEH

DATE 11/12/85

SD-2422

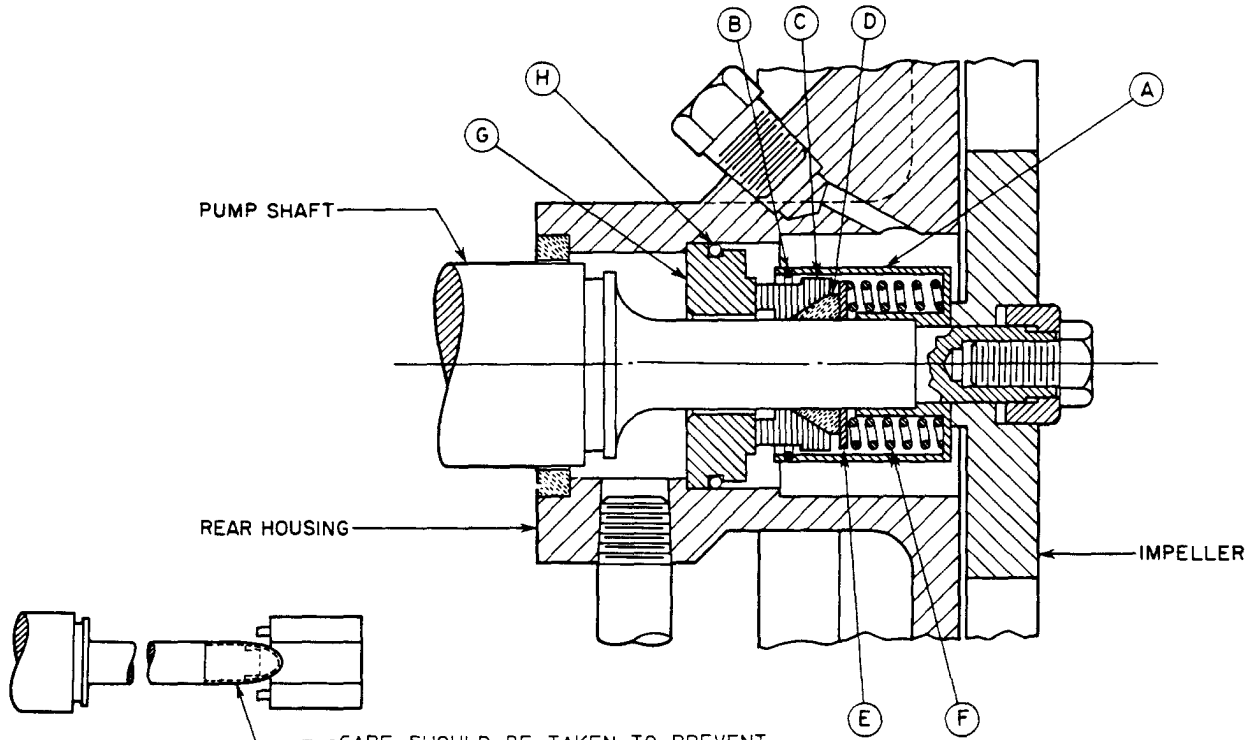

CARE SHOULD BE TAKEN TO PREVENT DAMAGE TO WEDGE WHEN INSTALLING SEAL HEAD. IT IS RECOMMENDED THAT A "BULLET" BE USED.

BASIC SEAL HEAD MATERIAL

SEAL HEAD ASSEMBLY	
ITEM	DESCRIPTION
A	RETAINER
B	RETAINING RING
37	SEAL FACE
	C OR CARBON TFE
D	WEDGE
E	DISC
F	SPRING

SEAL SEAT W/O-RING	
ITEM	DESCRIPTION
39	G OR METALLIC CERAMIC
	H O-RING, SEAT

ECO	Pulsafeeder
SINGLE SEAL (K, S AND T) ALLOY C C10 CENTRIFUGAL PUMPS	

03/93	B	CHANGE TITLE	DWN. BY: RCS
11/91	A	UPDATE CHART	DATE 9-25-86

SD-2424

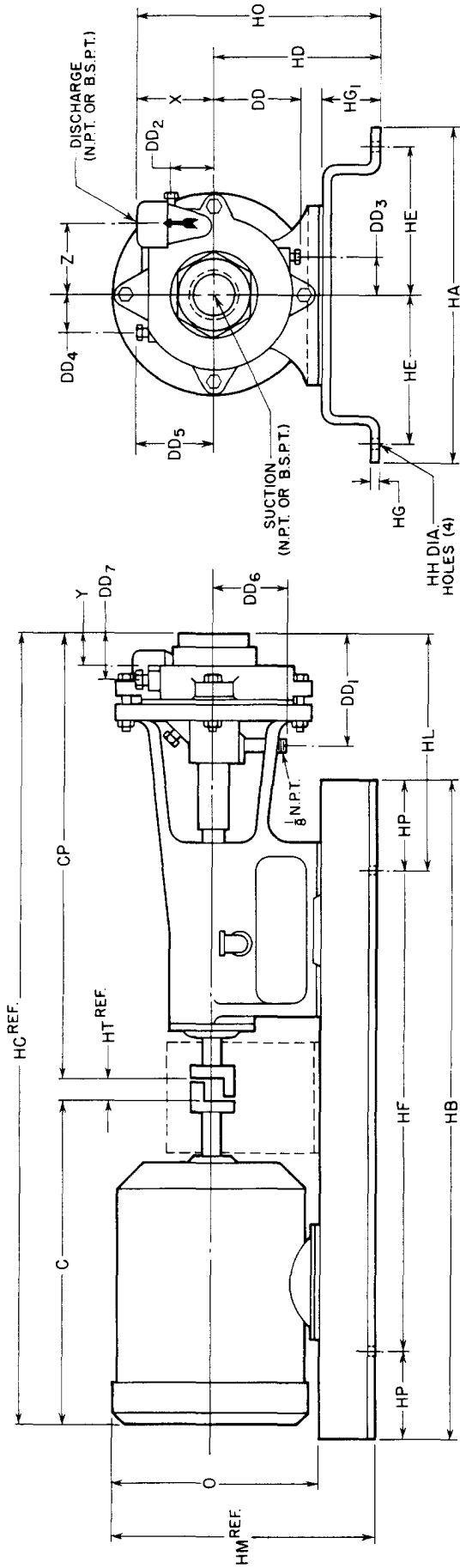

		DIMENSIONS																											
		INCHES																											
		MM																											
SUCT	DISCH	C	CP	DD	DD ₁	DD ₂	DD ₃	DD ₄	DD ₅	DD ₆	DD ₇	HA	HB	HC	HD	HE	HF	HG	HG ₁	HH	HL	HM	HO	HP	HT	O	X	Y	Z
1	3/4	14 1/16	2 5/8	3 5/8	2 5/8	2 5/16	1 1/4	2 3/16	2 5/16	1 1/2	12 1/2	24	5 3/16	5 3/4	18	3 1/16	1 1/16	1 1/16	13 3/32	6 1/16	201.6	7 15/16	3	3/4		2 3/4	1 1/4	2 1/4	
		357.2	66.6	92.0	66.6	25.4	31.7	71.4	58.7	38.1	317.5	609.6	134.9	146.0	457.2	4.7	42.8	10.3	169.8		201.6	76.2	19.0			69.8	31.7	57.1	

NOTE: PRINTED DIMENSIONS SHOWN FOR MOTOR
FRAME SIZES 48, 56, 143T, 145T.

MOTOR DATA	FRAME	HP	RPM	PHASE / HZ / VOLTS
ENCLOSURE			MFR	

ECO **Pulsafeeder**

G-10 CENTRIFUGAL PUMP
END SUCTION
PEDESTAL MOUNTED
ON BASE PLATE

DWN BY: R C S
DATE 9-25-86

SD-2419

CUSTOMER _____ P.O. NO. _____

ECO ORDER NO. _____ PUMP MODEL _____

CERTIFIED BY _____ DATE _____

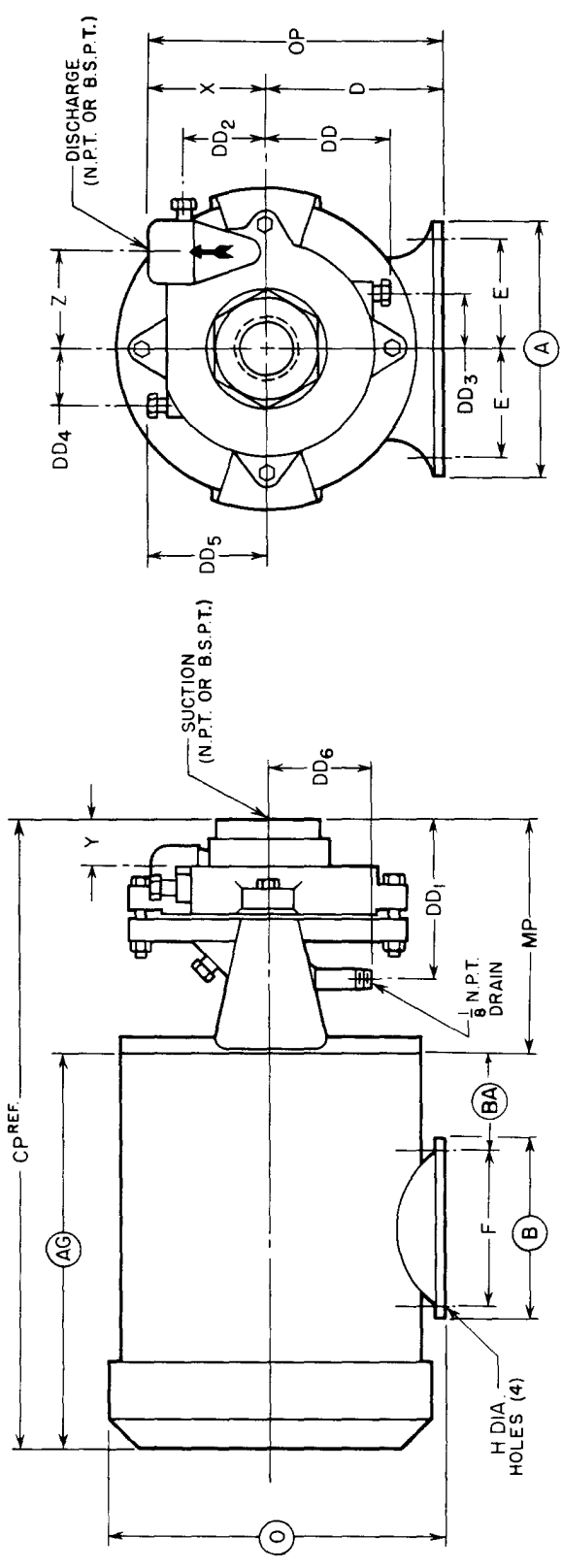

		DIMENSIONS												ENCLOSURE		MFR		DIMENSIONS SHOWN ON MOTOR DRAWING	
		INCHES						MM											
SUCT	DISCH	D	DD	DD1	DD2	DD3	DD4	DD5	DD6	E	F	H	MP	OP	X	Y	Z	CP	
1	3/4	3 1/2	2 5/8	3 5/8	2 5/8	1	1 1/4	2 3/16	2 5/16	2 1/16	3	1 1/32	6 1/2	6 1/4	2 3/4	1 1/4	2 1/4		
MOTOR DATE	FRAME 56	FACE C	HP	RPM	PHASE/HZ/VOLTS														
		88.9	66.6	92.0	66.6	25.4	31.7	71.4	58.7	61.9	76.2	8.7	165.1	158.7	69.8	31.7	57.1		

ECO **Pulsafeeder**

C-10 CENTRIFUGAL PUMP
END SUCTION
MOTOR MOUNTED

DWN BY: RCS
DATE 9-25-86

SD-2420

CUSTOMER _____ P.O. NO. _____

ECO ORDER NO. _____ PUMP MODEL _____ ITEM NO. _____

CERTIFIED BY _____ DATE _____

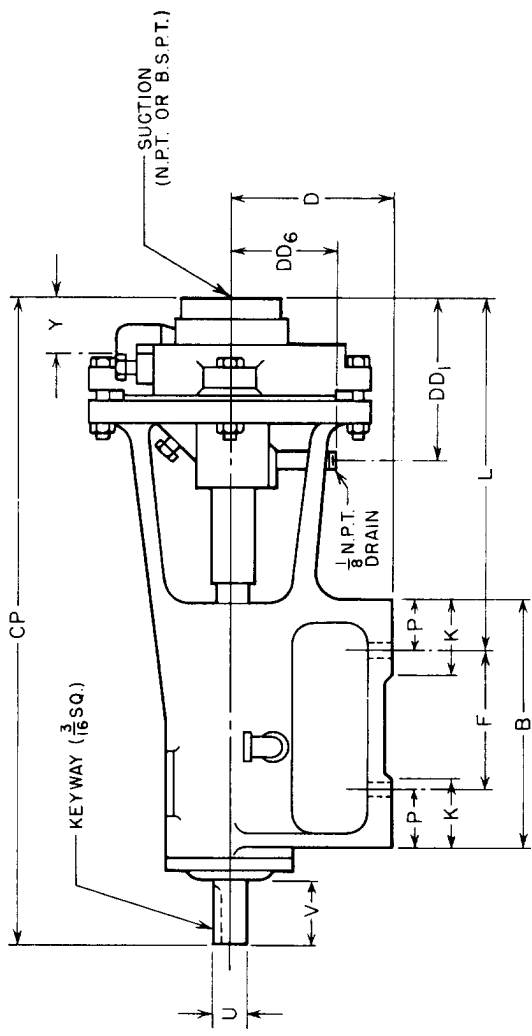
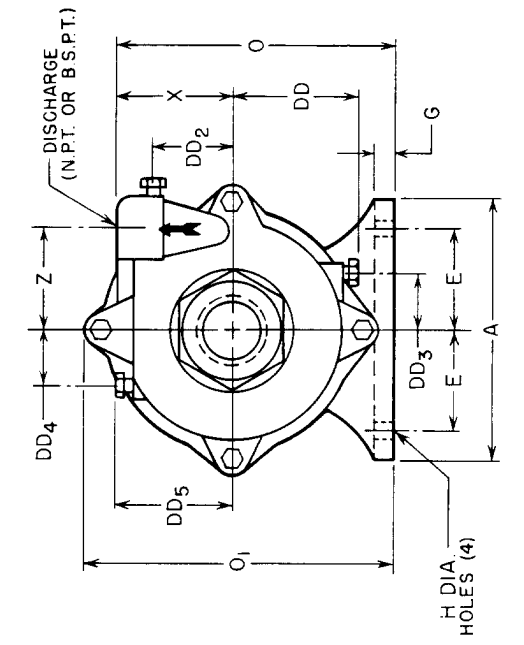

DIMENSIONS INCHES / MM

SUCT	DISCH	A	B	CP	D	DD	DD1	DD2	DD3	DD4	DD5	DD6	E	F	G	H	K	L	O1	O	P	U	V	X	Y	Z
I	3/4	6	5 3/4	14 1/16	3 1/2	2 5/8	3 5/8	2 5/8	1	1 1/4	2 13/16	2 5/16	2 1/4	3 1/4	1/2	1 1/32	1 3/4	7 7/16	6 1/4	6 1/4	1 1/4	3/4	1 1/2	2 3/4	1 1/4	2 1/4
		152.4	146.0	357.2	88.9	66.6	92.0	66.6	25.4	31.7	71.4	58.7	57.1	82.5	12.7	8.7	44.4	188.9	171.4	158.7	31.7	19.0	38.1	69.8	31.7	57.1

ECO **Pulsafeeder**

C-10 CENTRIFUGAL PUMP
END SUCTION
PEDESTAL MOUNTED

DWN BY: **RCS**
DATE: **9-25-86**

SD-2418

CUSTOMER _____ P.O. NO. _____

ECO ORDER NO. _____ PUMP MODEL _____ ITEM NO. _____

CERTIFIED BY _____ DATE _____

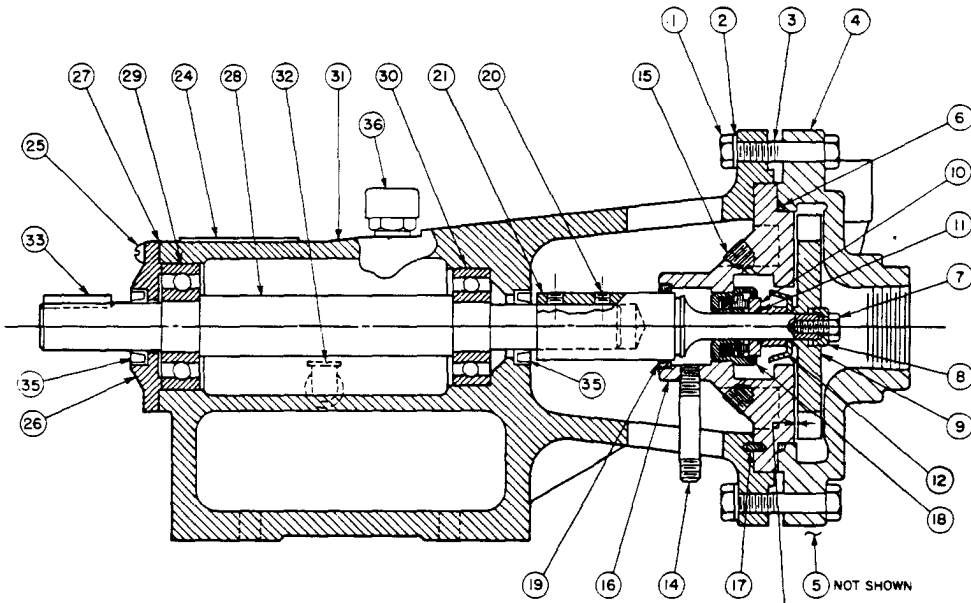

IMPELLER TO REAR HOUSING
CLEARANCE SET AT 0.017 INCHES.

PEDESTAL MOUNTED

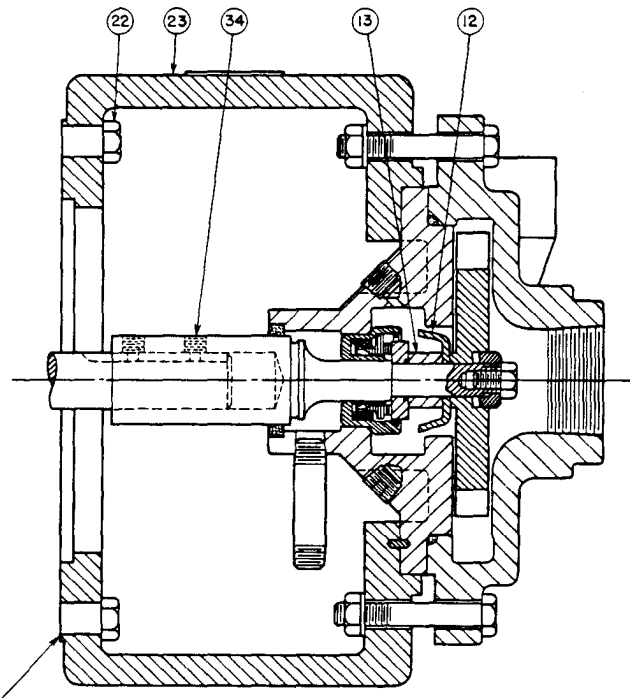

NEMA 56C MOTOR
MOUNTS AT THIS FLANGE.

MOTOR MOUNTED

ITEM	PART NAME
1	NUT, HOUSING BOLT
2	WASHER, HOUSING BOLT
3	BOLT, HOUSING
4	HOUSING, FRONT
5	PLUG, 1/8" NPT
6	GASKET, HOUSING
7	BOLT, IMPELLER RETAINING
8	COLLAR, IMPELLER DRIVE
9	IMPELLER
10	SEAL SEAT, ROTATING
11	O-RING, SEAL SEAT
12	SLINGER
13	SPACER, SLINGER
14	NIPPLE, 1/8" NPT
15	PLUG, 1/8" NPT
16	HOUSING, REAR
17	PIN, HOUSING
18	SEAL CARTRIDGE
19	FLANGE, DRAIN
20	SET SCREW, 1/4" CUP POINT
21	SHAFT, PUMP
22	BOLT, PUMP BRACKET
23	BRACKET, PUMP
24	NAMEPLATE
25	SCREW, BEARING CAP
26	CAP, BEARING
27	GASKET
28	SHAFT, PEDESTAL
29	BEARING, REAR
30	BEARING, FRONT
31	PEDESTAL
32	OIL CUP
33	KEY
34	SET SCREW, 1/4" DOG POINT
35	OIL SEAL
36	FITTING, AIR VENT

WETSEAL CONFIGURATION SHOWN FOR OTHER C10 SERIES
ARRANGEMENTS. SEE DRAWINGS SD-2381-2, SD-2422, SD-2424

ECO	Pulsafeeder
CROSS SECTION SINGLE WET SEAL (U, V AND W) C10 CENTRIFUGAL PUMPS	
DWN BY: RCS	
DATE 9-25-86	
SD-2421	

NO.	DATE	REVISIONS	BY
C	3-5-93	CHANGE TITLE	P.W.
B	11-01-91	UPDATE CHART	P.W.
A	2-13-79	ADDED AIR VENT FITTING ADDED OIL SEALS	AZ

C-10 CENTRIFUGAL PUMP

END SUCTION 1" X 3/4"

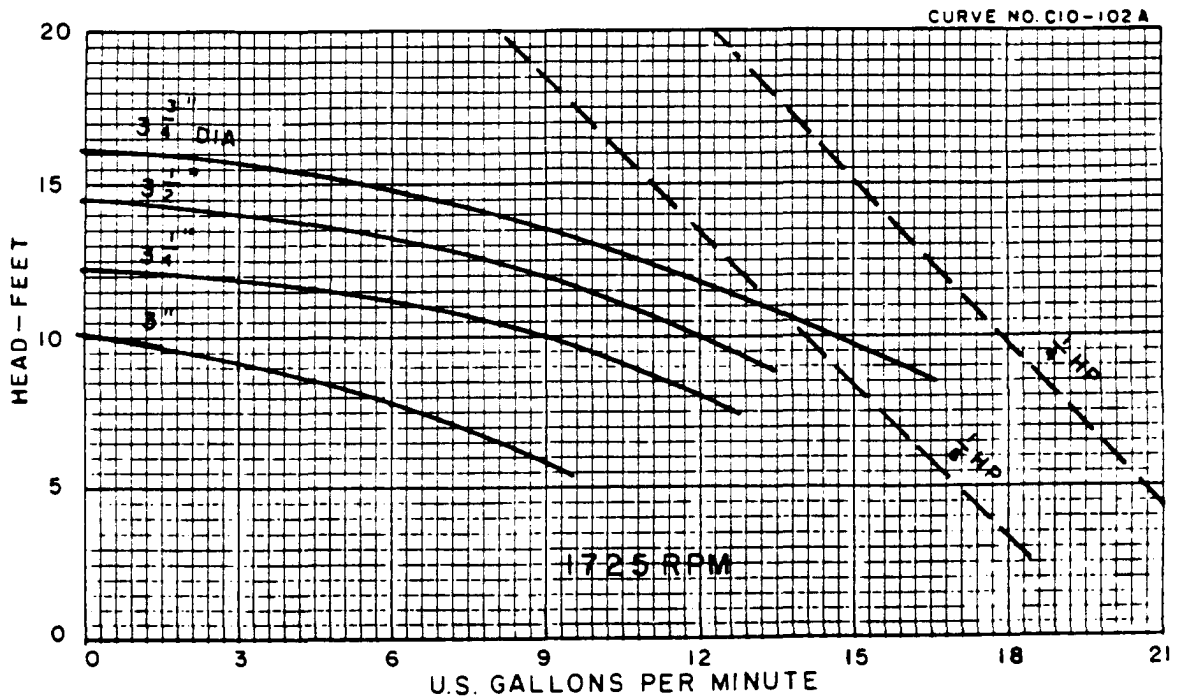
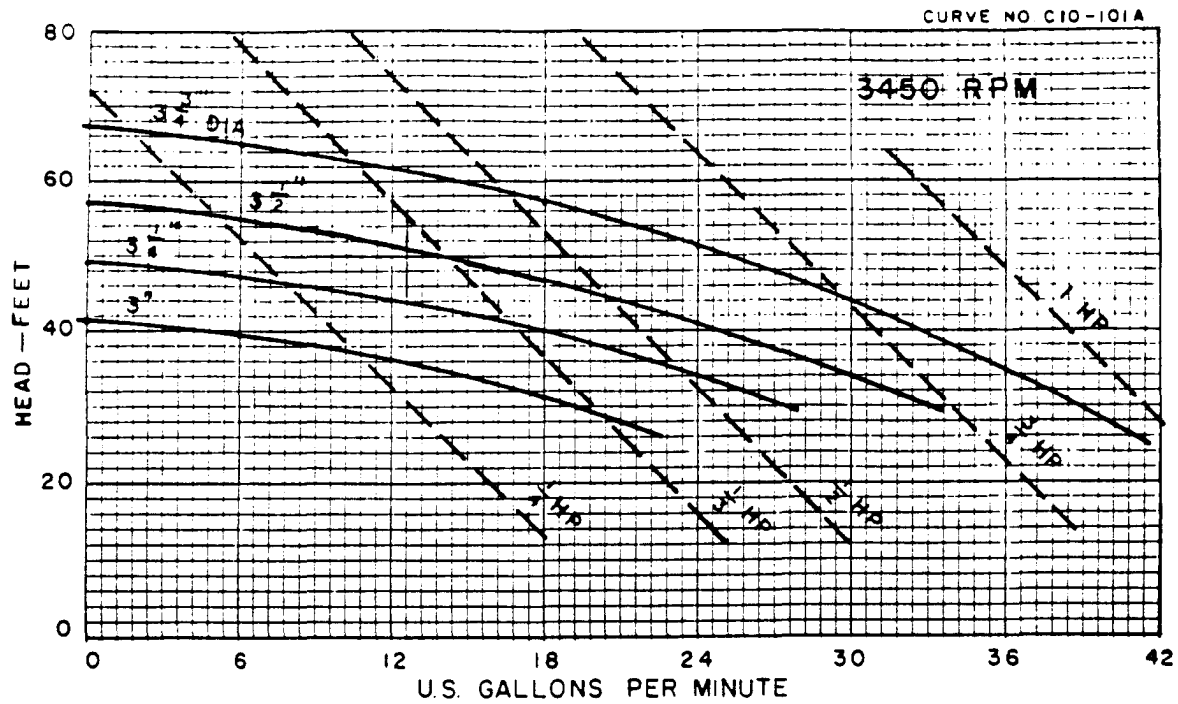

REV. A 12/29/76
ALL CURVES BASED ON WATER AT 70° F

PRINTED IN U.S.A.

C-10 CENTRIFUGAL PUMP

END SUCTION 1" X 3/4"

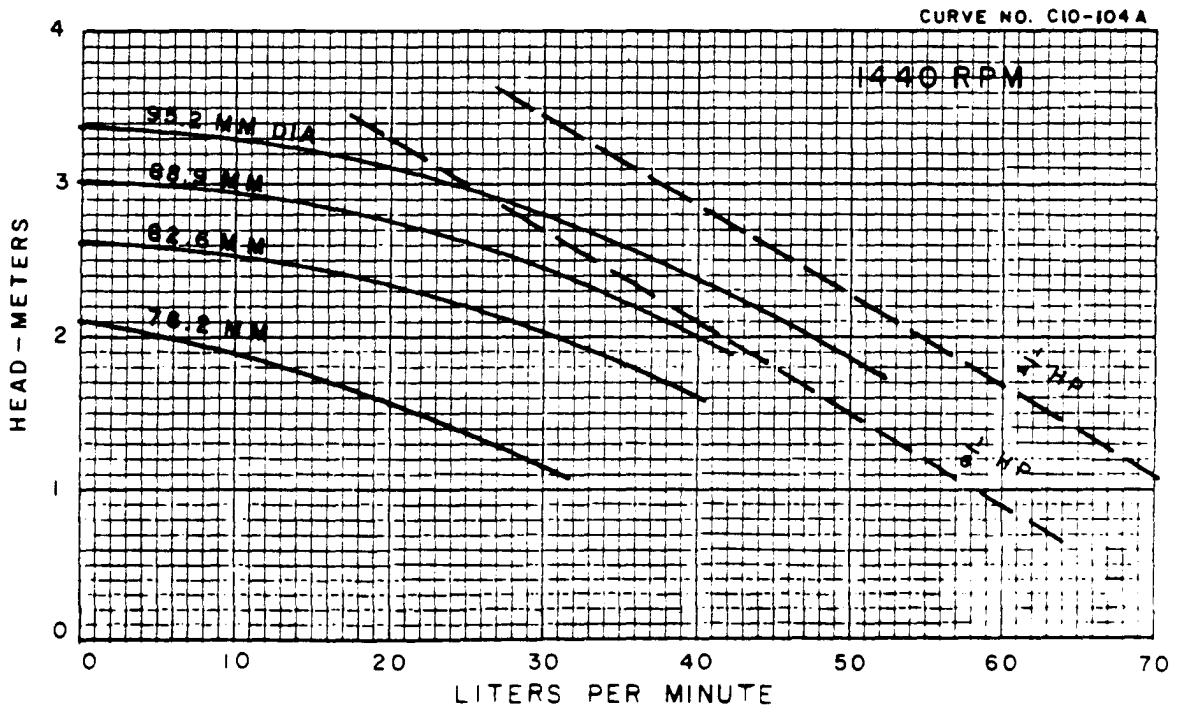
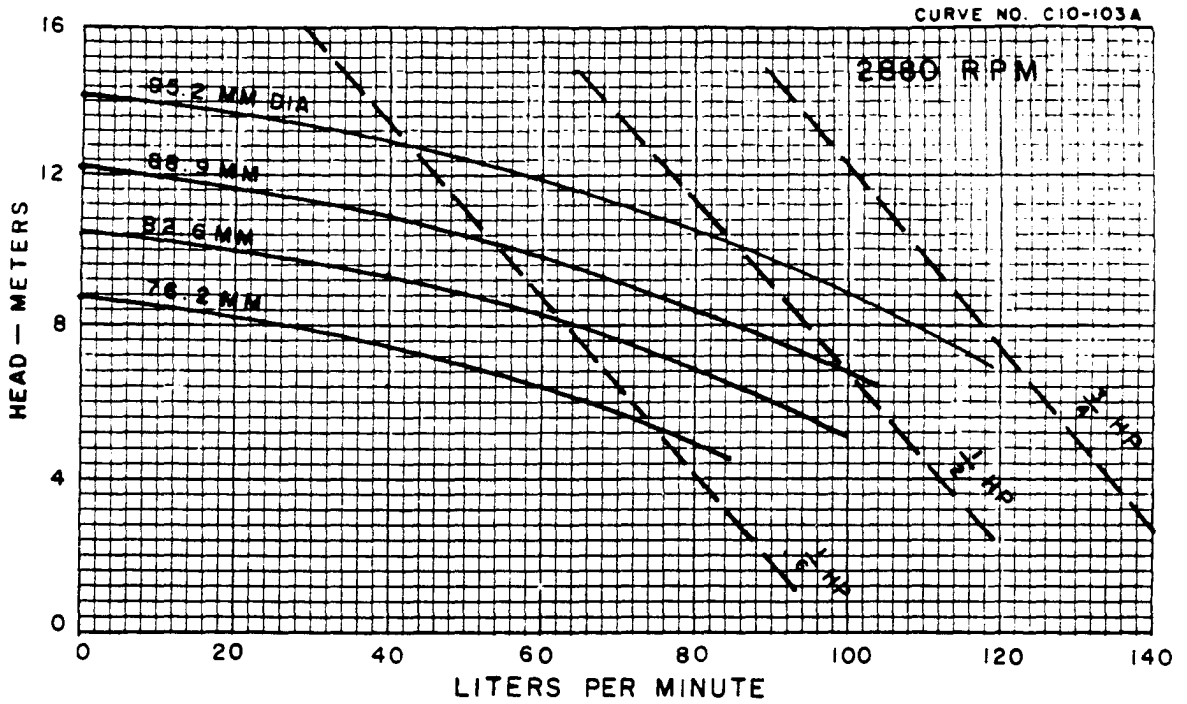

REV. A 12/29/76
ALL CURVES BASED ON WATER AT 70°F

PRINTED IN U.S.A.

ECO[®]

CENTRIFUGAL PUMP

IMC - 93 Rev A



Pulsafeeder, Inc

A unit of IDEX Corporation

2883 Brighton Henrietta Town Line Road

Rochester NY 14623

+1 (585) 292-8000

www.pulsafeeder.com

pulsa@idexcorp.com

