

PULSAFEEDER[®] ENGINEERED PRODUCTS

8480X

PULSA Series[®]

The big brother of the PULSA Series[®] family, the Model 8480X can pump over 2200 gph (8328 lph) and up to 3625 psi (250 bar). The PULSA Series 8480X was designed to provide years of dependable liquid metering. It features rugged, heavy duty construction combined with traditional PULSA Series precision. Like every PULSA Series pump, the 8480X is the result of over 70 years of pump research, development and testing. The PULSA Series 8480X is commonly used for applications in industries such as chemical processing, petrochemical, oil & gas and power. It is the first choice for quality, serviceability and economical cost of ownership.



Applications

corrosion inhibitors, anti-scalants, slurries, disinfection, pH and odor control



Flow

up to 2292 gph (8676 lph)



Pressure

up to 3625 psi (250 bar)



Temperature

up to 180°F (82°C)



API-675 • CE • ATEX

Hydraulic diaphragm metering delivers more than you expect.

Standard materials of construction

- Wet end: 316LSS, GF-PTFE, PVC
- Diaphragm: PTFE
- Pump body: Cast Iron
- Valve ball: 316LSS, Alumina Ceramic
- Valve gaskets: PTFE

Connection types

- NPT
- Raised-face Flange

Controls

- XAE - stroke length
 - ♦ NEMA Type 4X & Type 7
- VFD - motor speed

Leak detection

- PULSAAlarm[®]
 - ♦ Pressure based
 - ♦ IP66 NEMA Type 7/4X

Duplex configurations

Check valve design

- Three component
- Delivers exceptional performance
- Easily serviced
- Does not require piping removal
- Disc valves standard for high flow service

Flow & Pressure Envelope by Piston Size (inches)

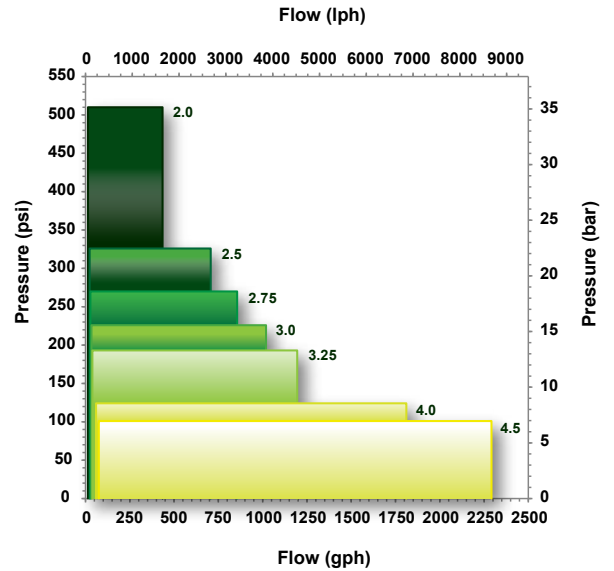
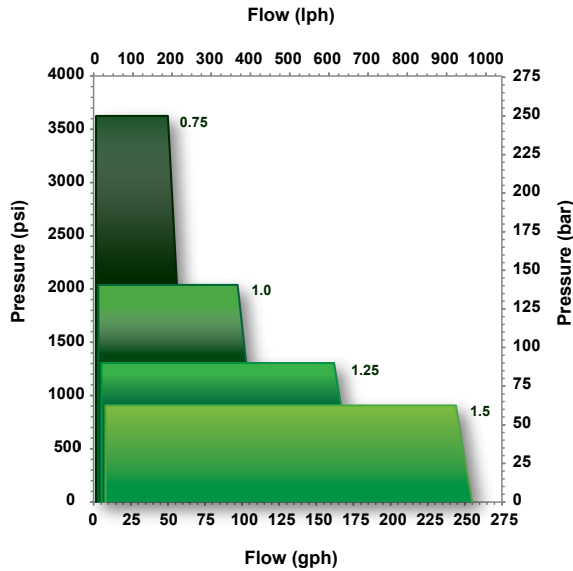

Features & Benefits

- Full motion stroke length control yields 0-100% linear flow adjustment over a 10:1 turndown range
- Hydraulically balanced diaphragm for long life and reduced service costs
- Proven hydraulic management system assures consistent performance and rapid recovery from system upsets
- Material options for safety, durability and chemical compatibility
- Sealed drive protects against atmospheric contamination and assures long service life
- Easy maintenance KOPkit® (Keep on Pumping kit) saves time and money

Custom Engineering

- Exotic materials: Alloy C, Alloy 20, Monel, DuplexSS, PVDF
- Extended temperature ranges
 - ♦ From -40°F (-40°C) to 700°F (371°C)
 - ♦ Remote heads and jackets
- Custom electronic controls
- Multiplex configurations
- Pneumatic stroke control
- HYDRAtube® design
- Extended pressures to 5000 psi / 345 bar
- Degassing valve
- Chemical feed systems
- Application consulting

Spec Pulsafeeder.
Get more than you expect.

Specifications

Materials	316LSS, PVC, GF-PTFE	Max temp	180°F (82°C)
Diaphragm type	Flat, Flat LD	Min temp	40°F (4.4°C)
Motor power	up to 10 hp (7.5 kW)	Accuracy	±1%
Motor frame	NEMA 182T/184T, 213/215T, IEC 90B3	Standards	API-675, CE, ATEX

Dimensions

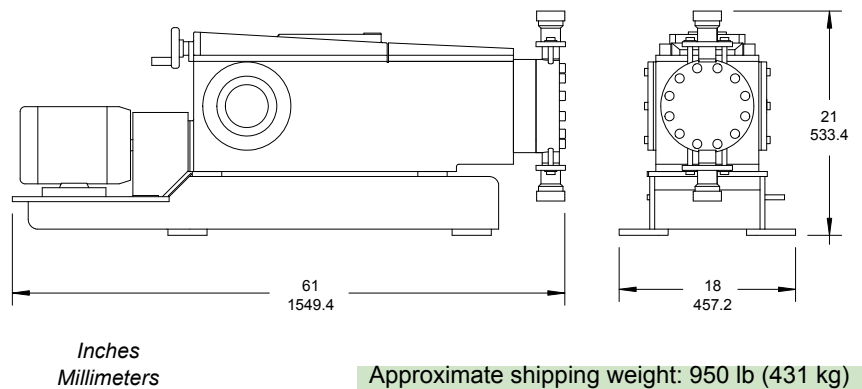

The dimensions shown may differ depending on pump configuration.

For More Information, Contact Your Authorized Pulsafeeder Engineered Products Representative

Pulsafeeder Engineered Products
2883 Brighton Henrietta Town Line Rd.
Rochester, NY 14623
Phone: +1 (585) 292-8000
pulsa@idexcorp.com • pulsafeeder.com

Pulsafeeder is an ISO 9001 Certified Company.

© Copyright 2026 Pulsafeeder. All rights reserved.

