

PulsaPro® 7120

HYDRAULIC DIAPHRAGM METERING PUMP

PulsaPro® 7120 is a positive displacement, leak-free, hydraulically balanced diaphragm metering pump, engineered for precise dosing and long-term dependability, delivering superior value. It offers a diverse range of fluid handling solutions with unique wet end designs consisting of HYDRAtube® or flat diaphragm types, each available in a variety of wet-end materials. PulsaPro simplifies startup and maintenance with features that monitor hydraulic operation, oil life, and piston position. These tools allow for quick identification of pump blockages or service needs. Additionally, the hydraulic bypass valve has been repositioned for easier adjustment, and the intermediate head was enlarged to boost overall pump performance. It complies with the API 675 standard for use in oil & gas, petrochemical, chemical processing, power generation, and water & wastewater treatment industries. Certified by WQA as “NSF/ANSI/CAN 61” compliant for use in drinking water treatment processes.



Common Applications

- corrosion inhibitors
- anti-scalants
- odor control
- Disinfection with Sodium Hypochlorite
- pH control with lime slurries



Flow

up to 243 gph (920 lph)



Pressure

up to 3,100 psi (213.7 bar)



Fluid Temperature

up to 250°F (121°C)



API 675, CE,
ATEX, IECEx



“NSF/ANSI/CAN 61”
“NSF/ANSI/372”



Standard materials of construction

- Wet end: 316LSS, GF-PTFE, PVC
- Diaphragm: PTFE, Hypalon* or Viton*
- Valve ball: 316LSS, Alumina Ceramic
- Valve seat: 316LSS, PVC, GF-PTFE
- Valve gaskets: PTFE, Hypalon* or Viton*
- Pump body: Cast Iron

Connection types

- NPT
- Raised-face flange

Controls

- Manual stroke length control
- Electronic stroke length control

* HYDRAtube only

Leak detection

- PULSAlarm®
 - Pressure based
 - IP66, NEMA Type 4X, NEMA TYPE 7

Automatic degassing

- HypoValve
 - Automatic purging of trapped gasses
 - Integrated Design
 - Use with Sodium Hypochlorite

Multiplex configurations available

- Ratio dosing
- Expanded dosing ranges

HYDRAtube design

- The solution for shear sensitive and high viscosity fluids
- Straight flow-through path
- Double diaphragm safety
- Optional slurry valves
- Robust Ductile Iron housing
- Elastomeric HYDRAtube
- ChemAlarm® leak detection

 **PULSAFEEDER®**

DIMENSIONS

Approximate shipping weight: 110 lb. (50 kg.)

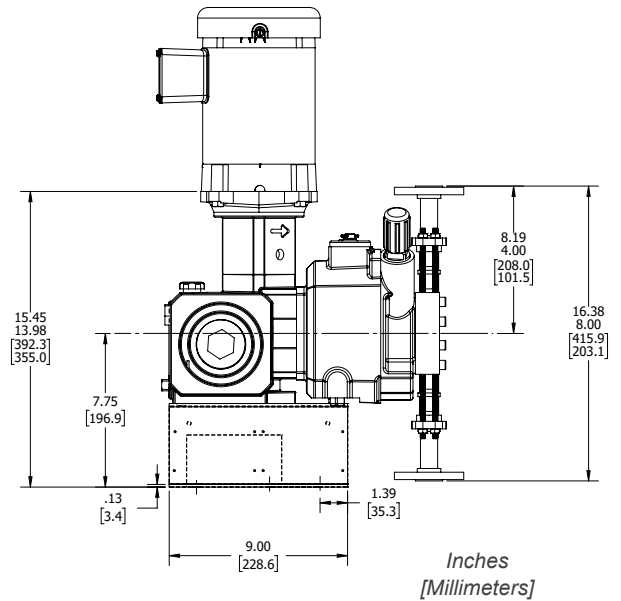
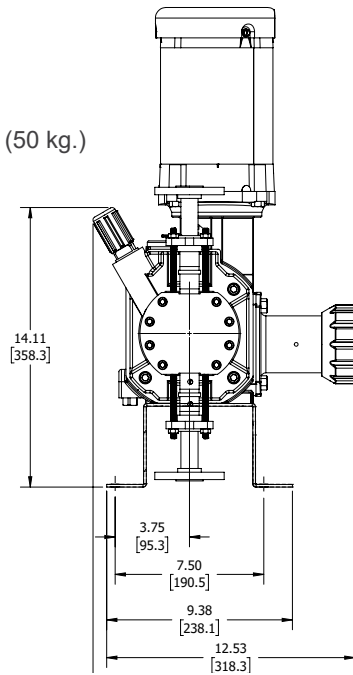

Inches
[Millimeters]
The dimensions given may differ depending on pump configuration.

SPECIFICATIONS

Materials	316LSS, PVC, GF-PTFE	Accuracy	±0.5%	
Diaphragm type	Flat, Tube	Temperature limitations	Min	Max
Motor power	up to 1.5 hp (1.1 kW)	Standard Fluid temp. range	-10°F (-23°C)	250°F (121°C)
Motor frame	NEMA 56C, 143/5TC, 182/4TC IEC 71B14, 80B14, 90B14	Ambient temp. limit with ATEX	-4°F (-20°C)	174°F (79°C)
		Standards	API 675, CE, ATEX, IECEx, "NSF/ANSI/CAN 61"	

FEATURES & BENEFITS

- Unique 3 valve hydraulic management system makes the PulsaPro pump resilient to system upset
 - **Hydraulic performance valve** maintains optimum diaphragm position and allows low NPIP of 5 psi (0.31 bar)
 - **Push-to-prime valve** allows quick manual priming of the hydraulic system in addition to automatic air bleeding
 - Externally adjustable **hydraulic by-pass valve** protects against over-pressurization
- **Diagnostic Performance Window:** Confirm proper hydraulic operation; Observe pump blockage condition; Monitor state of oil life; Validate piston operation and position for ease of service
- Four bolt tie bar design provides ultimate resistance to piping moments and forces
- Three component check valves for controlled fluid displacement, assuring reliable hydraulic operation
- Manual stroke length adjustment with resolution of 0.1% for set point accuracy and optional electronic stroke length adjustment with 5x improved resolution

FLOW & PRESSURE ENVELOPE

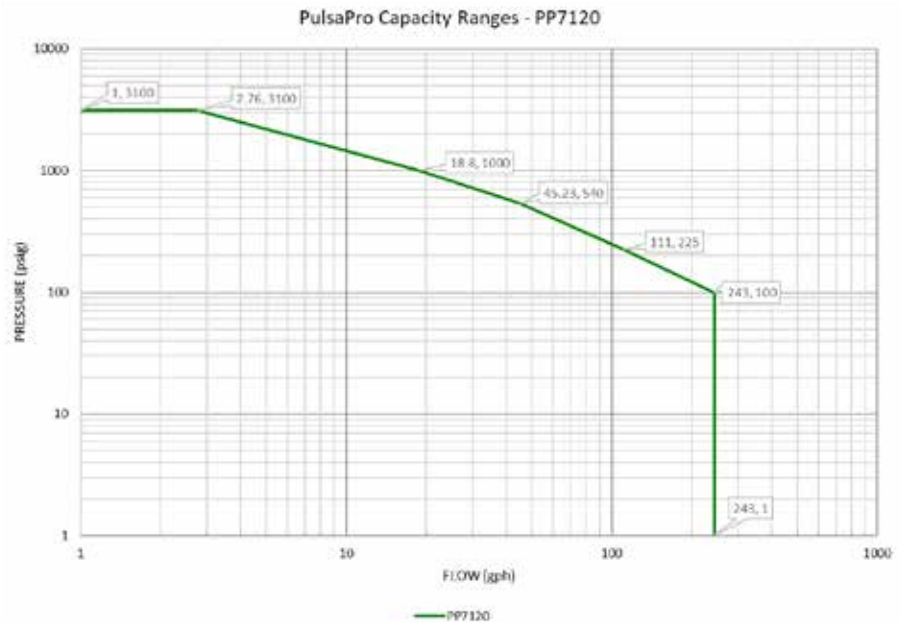

CUSTOM ENGINEERING

- Compatible materials: Alloy C, Alloy 20, Monel®, DuplexSS, Titanium, PVDF
- Minimum temperature to -10°F (-23°C) and with ATEX to -4°F (-20°C)
- Degass Valve
- Chemical feed systems
- Application consulting

Pulsafeeder, Inc.
2883 Brighton Henrietta Town Line Rd.
Rochester, NY 14623
Phone: +1 (585) 292-8000
pulsa@idexcorp.com • pulsafeeder.com

Pulsafeeder is an ISO 9001 Certified Company.

pulsa7120spec_Rev0226